



# Cryogenic Valves

For Industrial Gas Applications



ENGINEERING YOUR SUCCESS.



# Contents

Follow Parker Process Control on:



Cryogenic Bronze Manual Globe Valve	<b>Page 4</b>
Cryogenic Full Stainless Steel Globe Valve	<b>Page 8</b>
Cryogenic Stainless Steel Globe Valve	<b>Page 12</b>
Cryogenic Actuated Globe Valve	<b>Page 20</b>
Cryogenic Manifold Fill Assemblies	<b>Page 22</b>
Cryogenic Stainless Steel Manual Gate Valve	<b>Page 26</b>
Cryogenic Stainless Steel Actuated Gate Valve	<b>Page 28</b>
Cryogenic Bronze Ball Valve	<b>Page 30</b>
Cryogenic Stainless Steel Ball Valve	<b>Page 32</b>
Cryogenic Wafer Ball Valve	<b>Page 34</b>
Cryogenic Actuated Bronze Ball Valve	<b>Page 36</b>
Cryogenic Actuated Stainless Steel Ball Valve	<b>Page 38</b>
Cryogenic Safety Relief Valve	<b>Page 40</b>
Cryogenic Thermal Relief Valve	<b>Page 44</b>
Cryogenic Pressure Regulator	<b>Page 46</b>
Cryogenic Pressure Build Up Valve	<b>Page 50</b>
Cryogenic Lift Check Valve	<b>Page 52</b>
Cryogenic Swing Check Valve	<b>Page 56</b>
Cryogenic Strainer	<b>Page 58</b>
Automatic Sensing Pressure Reversing Obturator	<b>Page 62</b>
Flow Diverter Ball Valve	<b>Page 64</b>
Flow Diverter Globe Valve	<b>Page 68</b>
Low Flow Protection Switch - Truflo	<b>Page 70</b>
Water Flow Controller - Constaflor	<b>Page 72</b>
Spares Kits	<b>Page 74</b>

# Cryogenic Bronze Manual Globe Valve

Bolted Bonnet - Extended Stem  
Bronze Body with Bronze Internals  
DN6 - DN50 (1/4" - 2")

The Parker Bestobell range of extended globe valves have been designed to eliminate leakages, maximize lifetime operation and reduce maintenance and spares cost.

The range is available with either screwed ends, Socket Ends or stubs and utilizes Parker Bestobell's unique independent bonnet and flange design, eliminating leakage through the flange gasket.

The Bronze extended stem globe valve has a bolted bonnet, integral cone seat and renewable seal, complete with bronze internals. Available with various ends, the valve is of the cone seat design for drop tight shut off. The bolted bonnet allows easy maintenance, even in confined spaces.

All valves are degreased for oxygen duty, assembled in clean room conditions and pressure tested prior to dispatch.

## Maximum Working Pressure (MWP)

Subject to end connections

Up to 50 bar (725 psi) at -196°C to +65°C

## Features

- Unique Parker Bestobell loose flange bolted bonnet design allows for thermal expansion and contraction and eliminates leakage at the bonnet gasket
- PTFE/PCTFE seal to ensure tight shut off at all times
- Designed and engineered specifically for cryogenic service
- Anti-blowout stem and one-piece high strength design for operator safety
- Long life, low torque stem thread
- Lightweight ergonomic aluminium hand wheel
- Screwed and welded high strength extension tube/bonnet joints
- Revolving disc ensures non-rotating seat contact for an extended leak free life
- Full bore
- Fast/easy maintenance of PTFE/PCTFE components
- Long life spring loaded gland packing

## Technical

- Designed and engineered for use with Group 1 gases.
- Designed and manufactured in accordance with ASTM B31.1, BS EN 1626 and BS ISO 21011.
- Optional full material traceability backed by BS EN 10204 3.1/3.2 certification.

CE Marked according to the Pressure Equipment Directive



DN15 Bronze Globe Valve  
Extended Stem with Socket Ends



DN40  
Screwed Ends



DN15 Stainless  
Steel Stubs

## Materials

	<b>Bronze</b>
1. Body	Gun Metal BS EN 1982 CC491K
2. Cover	Stainless Steel BS EN 10088-3 1.4301
3. Bonnet Flange	Stainless Steel ASTM A351 CF8M
4. Disc	HT Brass BS EN 12164 CW 721R
5. Stem	Stainless Steel BS EN 10088-3 1.4401
6. Gasket Bonnet	Sigma 511
7. Gland Packing	Virgin PTFE
8. Fasteners	Stainless Steel BS6105 A2/A4 Gr.70
9. Seal	Virgin PTFE/PCTFE
10. Tube	Stainless Steel ASTM A312 TP304L

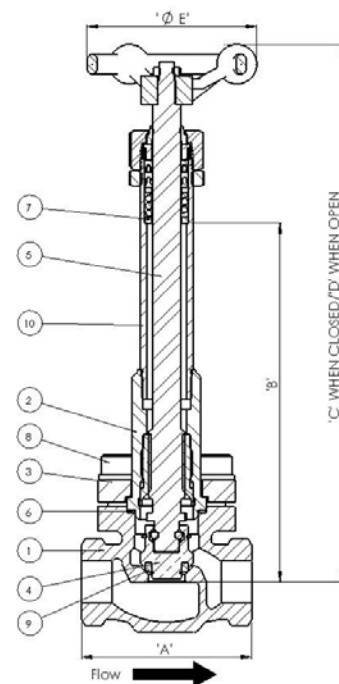

## Specifications

Size	Unit	DN6 1/4"	DN10 3/8"	DN15 1/2"	DN20 3/4"	DN25 1"	DN40 1 1/2"	DN50 2"
A	mm	68	68	68	76	92	121	146
B	mm	230/300	230/300	230/300	230/300	230/300	230/300	230/300
C : Closed	mm	300/370	300/370	300/370	300/370	310/380	310/380	310/380
D : Open	mm	310/380	310/380	310/380	310/380	320/390	320/390	330/400
E	mm	80	80	80	80	101	121	144
Cv	US GPM	3.6	3.6	3.6	6.2	13.2	26.5	43
Weight	kg	1.5	1.5	1.5	2.5	2.5	4.5	7.6

## How to Order

The correct part number is easily derived from the following number sequence

<b>CNB</b>	<b>10</b>	<b>TA</b>	<b>D</b>	<b>3</b>	<b>C</b>
Series	Valve Size Diameter Nominal (DN)	Connection Type	Stem Type	Stem Length	Seat
<b>CNB</b> Cryogenic Globe Valve - Bronze	<b>10</b> DN6	<b>TA</b> BSP-PL <b>TC</b> BSP-TR <b>TE</b> NPT <b>SST</b> Stainless Steel Stubs	Bolted Bonnet - Extended Stem	<b>3</b> 230 mm <b>6</b> 300 mm	<b>C</b> Cone
	<b>20</b> DN10				
	<b>30</b> DN15				
	<b>40</b> DN20				
	<b>50</b> DN25				
	<b>70</b> DN40				
	<b>80</b> DN50				

**Notes:** For Schedule 10 Stubs (Stainless Steel option only) insert Q2 at the end of part number. Please contact us for other options.

# Cryogenic Bronze Manual Globe Valve

Bolted Bonnet - Non-Extended Stem

Bronze Body with Bronze Internals

DN6 - DN50 (1/4" - 2")

The Parker Bestobell range of non-extended globe valves have been designed to eliminate leakages, maximize lifetime operation and reduce maintenance and spares cost.

The range is available with either screwed ends, Socket Ends or stubs and utilizes Parker Bestobell's unique independent bonnet and flange design, eliminating leakage through the flange gasket.

The Bronze non-extended stem globe valve has a bolted bonnet, integral cone seat and renewable seal, complete with bronze internals. Available with various ends, the valve is of the cone seat design for drop tight shut off. The bolted bonnet allows easy maintenance, even in confined spaces.

All valves are degreased for oxygen duty, assembled in clean room conditions and pressure tested prior to dispatch.

## Maximum Working Pressure (MWP)

Subject to end connections

Up to 50 bar (725 psi) at -196°C to +65°C

## Features

- Unique Parker Bestobell loose flange bolted bonnet design allows for thermal expansion and contraction and eliminates leakage at the bonnet gasket
- PTFE/PCTFE seal to ensure tight shut off at all times
- Designed and engineered specifically for cryogenic service
- Anti-blowout stem and one-piece high strength design for operator safety
- Long life, low torque stem thread
- Lightweight ergonomic aluminium hand wheel
- Revolving disc ensures non-rotating seat contact for an extended leak free life
- Full bore
- Fast/easy maintenance of PTFE/PCTFE components
- Long life spring loaded gland packing

## Technical

- Designed and engineered for use with Group 1 gases.
- Designed and manufactured in accordance with ASTM B31.1, BS EN 1626 and BS ISO 21011.
- Optional full material traceability backed by BS EN 10204 3.1/3.2 certification.

CE Marked according to the Pressure Equipment Directive



DN25 Bronze Globe Valve Non-Extended Stem Globe Valve with Socket Ends



DN40  
Screwed Ends



DN25 Stainless Steel  
Stubs

## Materials

	<b>Bronze</b>
1. Body	Gun Metal BS EN 1982 CC491K
2. Cover	Stainless Steel BS EN 10088-3 1.4301
3. Bonnet Flange	Stainless Steel ASTM A351 CF8M
4. Disc	HT Brass BS EN 12164 CW 721R
5. Stem	Stainless Steel BS EN 10088-3 1.4401
6. Gasket Bonnet	Sigma 511
7. Gland Packing	Virgin PTFE
8. Fasteners	Stainless Steel BS6105 A2/A4 Gr.70
9. Seal	Virgin PTFE/PCTFE

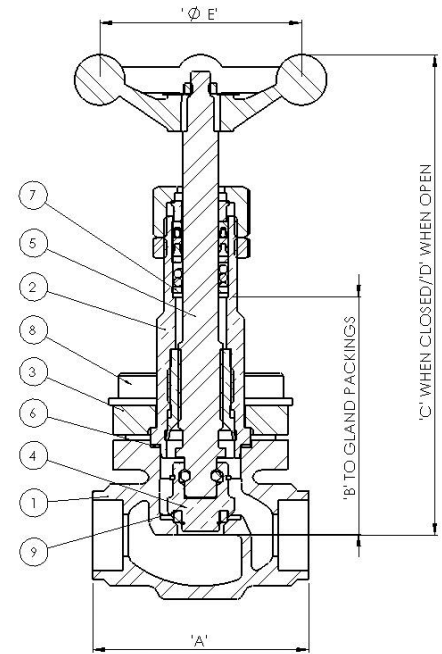

## Specifications

Size	Unit	DN6 1/4"	DN10 3/8"	DN15 1/2"	DN20 3/4"	DN25 1"	DN40 1 1/2"	DN50 2"
A	mm	68	68	68	76	92	121	146
B	mm	80	80	80	80	90	110	140
C: Closed	mm	150	150	150	170	170	190	230
D: Open	mm	160	160	160	180	180	200	240
E	mm	80	80	80	80	101	121	144
Cv	US GPM	3.6	3.6	3.6	6.2	13.2	26.5	43
Weight	kg	1	1	1	1.6	2	3.7	6

## How to Order

The correct part number is easily derived from the following number sequence

<b>CNB</b>	<b>10</b>	<b>TA</b>	<b>C1</b>	<b>C</b>
Series	Valve Size Diameter Nominal (DN)	Connection Type	Stem Type	Seat
<b>CNB</b> Cryogenic Globe Valve - Bronze	<b>10</b> DN6	<b>TA</b> BSP-PL	Bolted Bonnet - Non-Extended Stem	<b>C</b> Cone
	<b>20</b> DN10	<b>TC</b> BSP-TR		
	<b>30</b> DN15	<b>TE</b> NPT		
	<b>40</b> DN20	<b>SST</b> Stainless Steel Stubs		
	<b>50</b> DN25			
	<b>70</b> DN40			
	<b>80</b> DN50			

**Notes:** For Schedule 10 Stubs (Stainless Steel option only) insert Q2 at the end of part number. Please contact us for other options.

# Cryogenic Full Stainless Steel Globe Valve

Bolted Bonnet - Extended Stem

Full Stainless Steel

DN6 - DN50 (1/4" - 2")

The Parker Bestobell range of extended globe valves have been designed to eliminate leakages, maximize lifetime operation and reduce maintenance and spares cost.

The range is available with either Butt Weld, socket end or flanged options and utilizes Parker Bestobell's unique independent bonnet and flange design, eliminating leakage through the flange gasket.

This Stainless Steel extended stem globe valves feature bolted bonnet, integral cone seat and renewable seal, complete with Stainless Steel internals. The bolted bonnet allows easy maintenance, even in confined spaces. The valve is of the cone seat design for drop tight shut off.

All valves are degreased for oxygen duty, assembled in clean room conditions and pressure tested prior to dispatch.

## Maximum Working Pressure (MWP)

Subject to end connections

Up to 50 bar (725 psi) at -196°C to +65°C

## Features

- Unique Parker Bestobell loose flange bolted bonnet design allows for thermal expansion and contraction and eliminates leakage at the bonnet gasket
- PTFE/PCTFE seal to ensure tight shut off at all times
- Designed and engineered specifically for cryogenic service
- Anti-blowout stem and one-piece high strength design for operator safety
- Long life, low torque stem thread
- Lightweight ergonomic aluminium hand wheel
- Screwed and welded high strength extension tube/bonnet joints
- Revolving disc ensures non-rotating seat contact for an extended leak free life
- Full bore
- Fast/easy maintenance of PTFE/PCTFE components
- Long life spring loaded gland packing

## Technical

- Designed and engineered for use with Group 1 gases.
- Designed and manufactured in accordance with ASTM B31.1, BS EN 1626 and BS ISO 21011.
- Optional full material traceability backed by BS EN 10204 3.1/3.2 certification.

CE Marked according to the Pressure Equipment Directive



DN15 Stainless Steel Globe Valve  
Extended Stem  
with Socket Ends



DN50  
Flanged Ends



DN40 Butt  
Weld Ends



## Materials

	<b>Stainless Steel</b>
1. Body	Stainless Steel ASTM A351 CF8M
2. Cover	Stainless Steel BS EN 10088-3 1.4301
3. Bonnet Flange	Stainless Steel ASTM A351 CF8M
4. Seal	Virgin PTFE/PCTFE
5. Stem	Stainless Steel BS EN 10088-3 1.4401
6. Gasket Bonnet	Sigma 511
7. Gland Packing	Virgin PTFE
8. Tube	Stainless Steel ASTM A312 TP304L
9. Disc	Stainless Steel BS EN 10088-3 1.4401
10. Fasteners	Stainless Steel BS6105 A2/A4 Gr.70

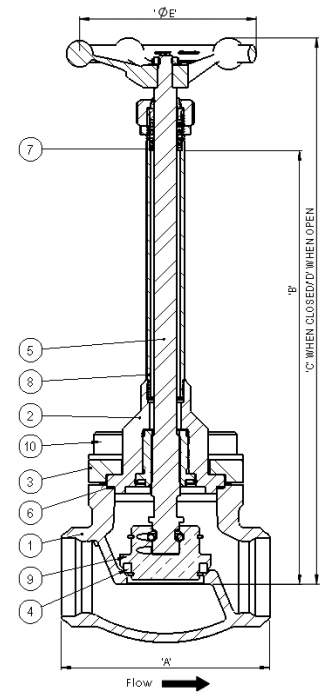

## Specifications

### Butt Weld Ends

Size	Unit	DN6 1/4"	DN10 3/8"	DN15 1/2"	DN20 3/4"	DN25 1"	DN40 1 1/2"	DN50 2"
A	mm	68	68	68	92	92	121	146
B	mm	300	300	300	300	300	300	300
C: Closed	mm	370	370	370	380	380	380	380
D: Open	mm	380	380	380	390	390	390	390
E	mm	80	80	80	80	101	121	144
Cv	US GPM	3.6	3.6	3.6	13.2	13.2	26.5	43
Weight	kg	1.6	1.6	1.6	2.3	2.3	4.2	6.8

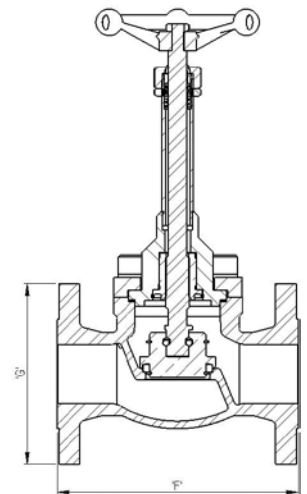

### Flanged Ends (Class 300)

Size	Unit	DN6 1/4"	DN10 3/8"	DN15 1/2"	DN20 3/4"	DN25 1"	DN40 1 1/2"	DN50 2"
F	mm	130	130	130	160	160	200	230
G	mm	95	95	95	124	124	155	165
Flange Thickness	mm	14	14	14	18	18	21	22
Weight	kg	2.8	2.8	2.8	5.3	5.3	9.6	13.8

\*Class 150 available on request

## How to Order

The correct part number is easily derived from the following number sequence

<b>CNS</b>	<b>10</b>	<b>B1</b>	<b>D</b>	<b>3</b>	<b>C</b>
Series	Valve Size - Diameter Nominal (DN)	Connection Type	Stem Type	Stem Length	Seat
<b>CNS</b> Cryogenic Globe Valve - Stainless Steel	<b>10</b> DN6	<b>B1</b> Butt Weld Schedule 10 <b>SN</b> Socket Weld <b>FA</b> Flange Class 150 <b>FC</b> Flange Class 300	Bolted Bonnet - Extended Stem	<b>3</b> 230mm	<b>C</b> Cone
	<b>20</b> DN10			<b>6</b> 300mm	
	<b>30</b> DN15				
	<b>40</b> DN20				
	<b>50</b> DN25				
	<b>70</b> DN40 <b>80</b> DN50				

Please contact us for other options.

# Cryogenic Full Stainless Steel Globe Valve

Bolted Bonnet - Non-Extended Stem

Full Stainless Steel

DN6 - DN50 (1/4" - 2")

The Parker Bestobell range of non-extended globe valves have been designed to eliminate leakages, maximize lifetime operation and reduce maintenance and spares cost.

The range is available with either Butt Weld, socket end or flanged options and utilizes Parker Bestobell's unique independent bonnet and flange design, eliminating leakage through the flange gasket.

The Stainless Steel non-extended stem globe valve has a bolted bonnet, integral cone seat and renewable seal, complete with Stainless Steel internals. Available with various ends, the valve is of the cone seat design for drop tight shut off. The bolted bonnet allows easy maintenance, even in confined spaces.

All valves are degreased for oxygen duty, assembled in clean room conditions and pressure tested prior to dispatch.

## Maximum Working Pressure (MWP)

Subject to end connections

Up to 50 bar (725 psi) at -196°C to +65°C

## Features

- Unique Parker Bestobell loose flange bolted bonnet design allows for thermal expansion and contraction and eliminates leakage at the bonnet gasket
- PTFE/PCTFE seal to ensure tight shut off at all times
- Designed and engineered specifically for cryogenic service
- Anti-blowout stem and one-piece high strength design for operator safety
- Long life, low torque stem thread
- Lightweight ergonomic aluminium hand wheel
- Revolving disc ensures non-rotating seat contact for an extended leak free life
- Full bore
- Fast/easy maintenance of PTFE/PCTFE components
- Long life spring loaded gland packing

## Technical

- Designed and engineered for use with Group 1 gases.
- ISO 9001 accreditation- design and manufacture to ASTM B31.1, BS EN 1626 and BS ISO 21011.
- Optional full material traceability backed by BS EN 10204 3.1/3.2 certification.

CE Marked according to the Pressure Equipment Directive



DN15 Full Stainless Steel  
Globe Valve – Non-Extended  
Stem with Socket Ends



DN25  
Flanged Ends



DN15 Butt  
Weld Ends

## Materials

	Stainless Steel
1. Body	Stainless Steel ASTM A351 CF8M
2. Cover	Stainless Steel BS EN 10088-3 1.4301
3. Bonnet Flange	Stainless Steel ASTM A351 CF8M
4. Disc	Stainless Steel BS EN 10088-3 1.4401
5. Stem	Stainless Steel BS EN 10088-3 1.4401
6. Gasket Bonnet	Sigma 511
7. Gland Packing	Virgin PTFE
8. Fasteners	Stainless Steel BS6105 A2/A4 Gr.70
9. Seal	Virgin PTFE/PCTFE

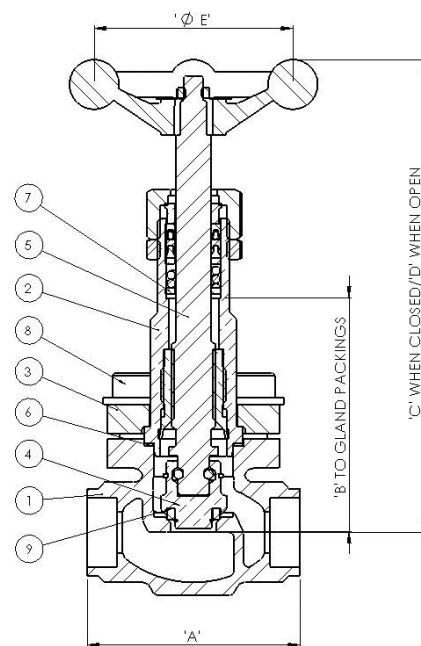

## Specifications

### Butt Weld Ends

Size	Unit	DN6 1/4"	DN10 3/8"	DN15 1/2"	DN20 3/4"	DN25 1"	DN40 1 1/2"	DN50 2"
A	mm	68	68	68	92	92	121	146
B	mm	80	80	80	80	90	110	140
C: Closed	mm	150	150	150	170	170	190	230
D: Open	mm	160	160	160	180	180	200	240
E	mm	80	80	80	101	101	121	144
Cv	US GPM	3.6	3.6	3.6	13.2	13.2	26.5	43
Weight	kg	1.2	1.2	1.2	2	2	3.7	5.8

### Flanged Ends (Class 300)

Size	Unit	DN6 1/4"	DN10 3/8"	DN15 1/2"	DN20 3/4"	DN25 1"	DN40 1 1/2"	DN50 2"
F	mm	130	130	130	160	160	200	230
G	mm	95	95	95	124	124	155	165
Flange Thickness	mm	14	14	14	18	18	21	22
Weight	kg	2.8	2.8	2.8	5.3	5.3	9.6	13.8

\*Class 150 available on request

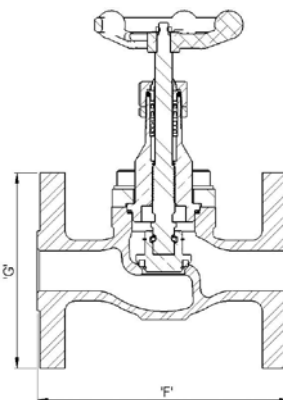

## How to Order

The correct part number is easily derived from the following number sequence

CNS	10	B1	C1	C
Series	Valve Size - Diameter Nominal (DN)	Connection Type	Stem Type	Seat
CNS Cryogenic Globe Valve - Stainless Steel	10	DN6	Bolted Bonnet - Non-Extended Stem	C Cone
	20	DN10		
	30	DN15		
	40	DN20		
	50	DN25		
	70	DN40		
	80	DN50		
		B1 Butt Weld Schedule 10 SN Socket Weld FA Flange Class 150 FC Flange Class 300		

Please contact us for other options.

# Cryogenic Stainless Steel Globe Valve

Bolted Bonnet - Extended Stem

Stainless Steel

DN65 - DN100 (2½" - 4")

The Parker Bestobell range of Stainless Steel extended globe valves have been designed to eliminate leakages, maximize lifetime operation and reduce maintenance and spares.

The range is available with Butt Weld, Socket Ends or flanged options and utilizes Parker Bestobell's unique independent bonnet and flange design, eliminating leakage through the flange gasket.

The Stainless Steel extended stem globe valve has a bolted bonnet, integral cone seat and renewable PTFE seal, complete with bronze internals. Available with various ends, the valve is of the cone seat design for drop tight shut off. The bolted bonnet allows easy maintenance, even in confined spaces.

All valves are degreased for oxygen duty, assembled in clean room conditions and pressure tested prior to dispatch.

## Maximum Working Pressure (MWP)

Subject to end connections

Up to 50 bar (725 psi) at -196°C to +65°C

## Features

- Unique Parker Bestobell loose flange bolted bonnet design allows for thermal expansion and contraction and eliminates leakage at the bonnet gasket
- Precision investment cast body – smooth surface finish
- PTFE seal to ensure tight shut off at all times
- Lightweight therefore excellent thermal characteristics and increased payload on mobile tanker application
- Designed and engineered specifically for cryogenic service
- Anti-blowout stem and one-piece high strength design for operator safety
- Long life, low torque stem thread
- Screwed and welded high strength extension tube / bonnet joints
- Revolving disc ensures non-rotating seat contact for an extended leak free life
- Fast/easy maintenance of PTFE/PCTFE components
- Long life spring loaded gland packing (Available on 2½" & 3")



DN65 Stainless Steel Globe Valve – Extended Stem with Socket Ends

## Technical

- Designed and engineered for use with Group 1 gases.
- Designed and manufactured in accordance with ASTM B31.1, BS EN 1626 and BS ISO 21011
- Optional full material traceability backed by BS EN 10204 3.1/3.2 certification.

CE Marked according to the Pressure Equipment Directive



DN80  
Butt Weld Ends



DN80  
Flanged Ends

### Materials

	<b>Stainless Steel</b>
1. Body	Stainless Steel ASTM A351 CF8M
2. Cover	Stainless Steel ASTM A351 CF8M
3. Loose Bonnet Flange	Stainless Steel ASTM A351 CF8M
4. Disc	HT Brass BS EN 12164 CW721R
5. Stem	Stainless Steel BS EN 10088-3 1.4401
6. Gasket	Sigma 511
7. Gland Packing	Virgin PTFE
8. Fasteners	Stainless Steel BS6105 A2/A4 Gr.70
9. Seal	Virgin PTFE
10. Tube	Stainless Steel ASTM A312 TP304L

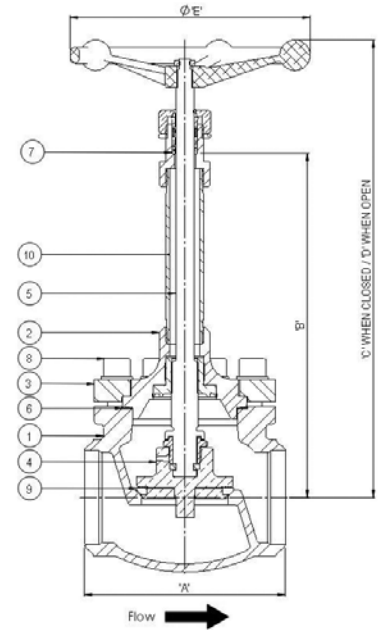

### Specifications

#### Butt Weld Ends

Size	Unit	DN65 2½"	DN80 3"	DN100 4"
A	mm	178	178	292
B	mm	300	300	400
C	mm	392	407	578
D	mm	412	437	613
E	mm	171	222	380
Weight	kg	13	15	55
Cv	US GPM	75	108	198



DN100 Butt Weld Ends

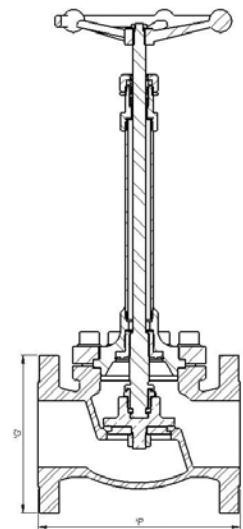

#### Flanged Ends (Class 300)

Size	Unit	DN65 2½"	DN80 3"	DN100 4"
F	mm	290	310	350
G	mm	191	210	254
Flange Thickness	mm	25	28	32
Weight	kg	21	27	74



DN100 Flanged Ends

\*Class 150 available on request

### How to Order

The correct part number is easily derived from the following number sequence

CNT	90	B1	D	4	C
Series	Valve Size - Diameter Nominal (DN)	Connection Type	Stem Type	Stem Length	Seat
CNT Cryogenic Globe Valve - Stainless Steel	90 DN65	B1 Butt Weld Schedule 10 SN Socket Weld FA Flange Class 150 FC Flange Class 300	Bolted Bonnet - Extended Stem	4 300	C Cone
	A0 DN80			7 400	
	B0 DN100				

Please contact us for other options.

# Cryogenic Stainless Steel Globe Valve

Bolted Bonnet – Extended Stem

Full Stainless Steel

DN150 & DN200 (6" & 8")

The Parker Bestobell range of extended globe valves have been designed to eliminate leakages, maximize lifetime operation and reduce maintenance and spares cost.

The range is available with either Butt Weld, socket end or flanged options and utilizes Parker Bestobell's unique independent bonnet and flange design, eliminating leakage through the flange gasket.

The Stainless Steel extended stem globe valves has a bolted bonnet, integral cone seat and renewable PTFE/PCTFE seal, complete with Stainless Steel internals. Available with various ends, the valve is of the cone seat design for drop tight shut off. The bolted bonnet allows easy maintenance, even in confined spaces.

All valves are degreased for oxygen duty, assembled in clean room conditions and pressure tested prior to dispatch.

## Maximum Working Pressure (MWP)

Subject to end connections

Up to 19 bar (275 psi) at -196°C to +65°C

## Features

- Unique Parker Bestobell loose flange bolted bonnet design allows for thermal expansion and contraction and eliminates leakage at the bonnet gasket
- Lightweight therefore excellent thermal characteristics
- Designed and engineered specifically for cryogenic service
- Anti-blowout stem and one-piece high strength design for operator safety
- Long life, low torque stem thread
- Screwed and welded high strength extension tube / bonnet joints
- Revolving disc ensures non-rotating seat contact for an extended leak free life
- Full bore
- Fast/easy maintenance of PTFE components

## Technical

- Designed and engineered for use with LNG.
  - Designed and manufactured in accordance with ASTM B31.1, BS EN 1626 and BS ISO 21011
  - Optional full material traceability backed by BS EN 10204 3.1/3.2 certification.
- CE Marked according to the Pressure Equipment Directive



DN150 Stainless Steel Globe Valve Extended Stem with Butt Weld Ends



DN150 with Flanged Ends



DN200 with Flanged Ends

## Materials

	Stainless Steel
1. Body	Stainless Steel ASTM A351 CF8M
2. Cover	Stainless Steel ASTM A351 CF8M
3. Disc	Stainless Steel ASTM A351 CF8M
4. Fasteners	Stainless Steel BS6105 A4 Gr.70
5. Seal	Hostaflon TF3105 25% Glass Fill PTFE
6. Extension Tube	Stainless Steel ASTM A312 TP304L
7. Stem	Stainless Steel BS EN 10088-3 1.4401
8. Gland Housing	Stainless Steel BS EN 10088-3 1.4401
9. Gland Follower	HT Brass BS EN 12164 CW721R
10. Gland Plate	HT Brass BS EN 12164 CW721R
11. Handwheel Boss	Aluminium BRZ BS EN 12163 CW307G
12. Handwheel	Cast Iron GR.250

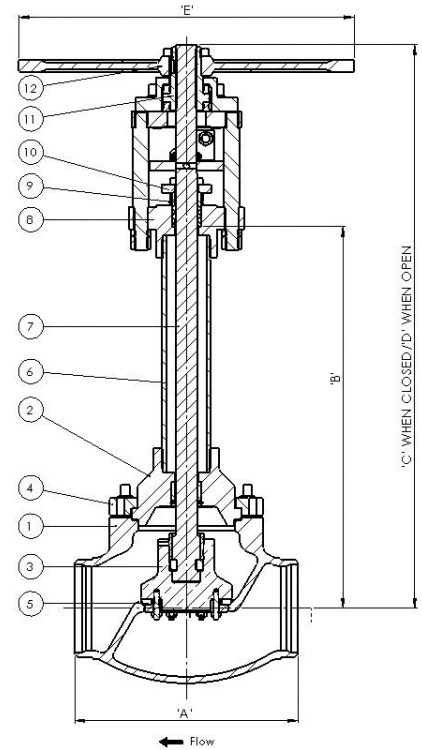

## Specifications

### Butt Weld Ends

Size	A (mm)	B (mm)	C (mm)	D (mm)	ØE (mm)	Cv (US GPM)	Weight (kg)
DN150	406	700	1023	1075	600	400	125
DN200	495	700	1363	1442	500	715	219

### Flanged Ends (Class 150)

Size	Unit	DN150 6"	DN200 8"
F	mm	406	495
G	mm	279	343
Flange Thickness	mm	25	28
Weight	kg	140	250

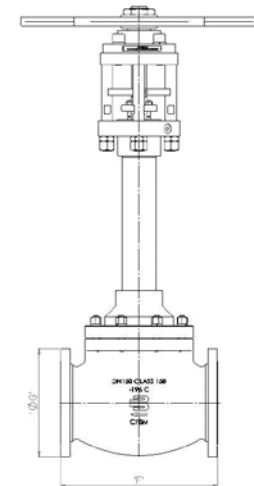

## How to Order

Part Number	Valve Size Diameter Nominal (DN)	Connection Type	Stem Length (mm)
CNTD0B1DDC	DN150	Butt Weld Schedule 10	700
CNTD0FADDC		Flange Class 150	
CNTE0B1DDC	DN200	Butt Weld Schedule 10	700
CNTE0FADDC		Flange Class 150	

Please contact us for other options.

# Cryogenic Stainless Steel Globe Valve

Bolted Bonnet - Extended Stem  
Stainless Steel Body with Bronze Internals  
DN6 - DN50 (1/4" - 2")

The Parker Bestobell range of extended globe valves have been designed to eliminate leakages, maximize lifetime operation and reduce maintenance and spares cost.

The range is available with either Butt Weld, socket end or flanged options and utilizes Parker Bestobell's unique independent bonnet and flange design, eliminating leakage through the flange gasket.

The Stainless Steel extended stem globe valve has a bolted bonnet, integral cone seat and renewable PTFE/PCTFE seal, complete with Stainless Steel internals. Available with various ends, the valve is of the cone seat design for drop tight shut off. The bolted bonnet allows easy maintenance, even in confined spaces.

All valves are degreased for oxygen duty, assembled in clean room conditions and pressure tested prior to dispatch.

## Maximum Working Pressure (MWP)

Subject to end connections

Up to 50 bar (725 psi) at -196°C to +65°C

## Features

- Unique Parker Bestobell loose flange bolted bonnet design allows for thermal expansion and contraction and eliminates leakage at the bonnet gasket
- PTFE/PCTFE seal to ensure tight shut off at all times
- Designed and engineered specifically for cryogenic service
- Anti-blowout stem and one-piece high strength design for operator safety
- Long life, low torque stem thread
- Lightweight ergonomic aluminium handwheel
- Screwed and welded high strength extension tube / bonnet joints
- Revolving disc ensures non-rotating seat contact for an extended leak free life
- Full bore
- Fast/easy maintenance of PTFE/PCTFE components
- Long life spring loaded gland packing

## Technical

- Designed and engineered for use with Group 1 gases.
- Designed and manufactured in accordance with ASTM B31.1, BS EN 1626 and BS ISO 21011
- Optional full material traceability backed by BS EN 10204 3.1/3.2 certification.

CE Marked according to the Pressure Equipment Directive



DN15 Stainless Steel Globe Valve - Extended Stem with Bronze Internals and Butt Weld Ends



DN50 Butt Weld Ends



DN50 Butt Weld Ends Sectioned View



## Materials

	<b>Stainless Steel</b>
1. Body	Stainless Steel ASTM A351 CF8M
2. Cover	Stainless Steel BS EN 10088-3 1.4301
3. Bonnet Flange	Stainless Steel ASTM A351 CF8M
4. Seal	Virgin PTFE/PCTFE
5. Stem	Stainless Steel BS EN 10088-3 1.4401
6. Gasket Bonnet	Sigma 511
7. Gland Packing	Virgin PTFE
8. Tube	Stainless Steel ASTM A312 TP304L
9. Disc	HT Brass BS EN 12164 CW721R
10. Fasteners	Stainless Steel BS6105 A2/A4 Gr.70

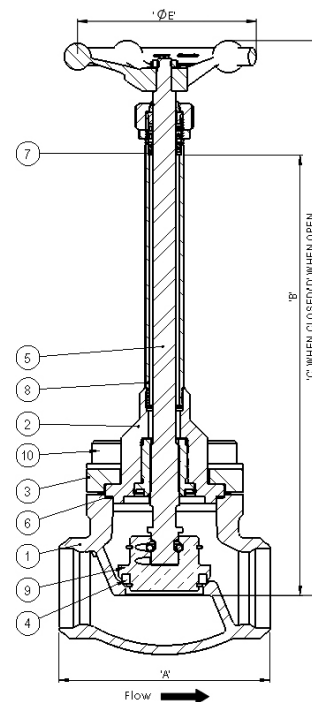

## Specifications

### Butt Weld Ends

Size	Unit	DN6 1/4"	DN10 3/8"	DN15 1/2"	DN20 3/4"	DN25 1"	DN40 1 1/2"	DN50 2"
A	mm	68	68	68	92	92	121	146
B	mm	230/300	230/300	230/300	230/300	230/300	230/300	230/300
C : Closed	mm	300/370	300/370	300/370	310/380	310/380	310/380	310/380
D : Open	mm	310/380	310/380	310/380	320/390	320/390	320/390	320/390
E	mm	80	80	80	101	101	121	144
Cv	US GPM	3.6	3.6	3.6	13.2	13.2	26.5	43
Weight	kg	1.6	1.6	1.6	2.3	2.3	4.2	6.8

### Flanged Ends (Class 300)

Size	Unit	DN6 1/4"	DN10 3/8"	DN15 1/2"	DN20 3/4"	DN25 1"	DN40 1 1/2"	DN50 2"
F	mm	130	130	130	160	160	200	230
G	mm	95	95	95	124	124	155	165
Flange Thickness	mm	14	14	14	18	18	21	22
Weight	kg	2.8	2.8	2.8	5.3	5.3	9.6	13.8

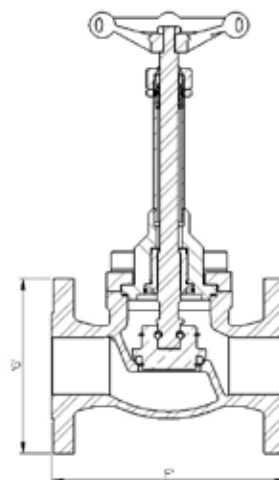

\*Class 150 available on request

## How to Order

The correct part number is easily derived from the following number sequence

CNT	10	B1	D	3	C
Series	Valve Size - Diameter Nominal (DN)	Connection Type	Stem Type	Stem Length	Seat
CNT Cryogenic Globe Valve - Stainless Steel	10 DN6	B1 Butt Weld Schedule 10	Bolted Bonnet - Extended Stem	3 230	C Cone
	20 DN10	SN Socket Weld		6 300	
	30 DN15	FA Flange Class 150			
	40 DN20	FC Flange Class 300			
	50 DN25				
	70 DN40				
	80 DN50				

Please contact us for other options.

# Cryogenic Stainless Steel Globe Valve

Bolted Bonnet – Non-Extended Stem

Stainless Steel Body with Bronze Internals

DN6 - DN50 (1/4" - 2")

The Parker Bestobell range of non-extended globe valves have been designed to eliminate leakages, maximize lifetime operation and reduce maintenance and spares cost.

The range is available with either Butt Weld, socket end or flanged options and utilizes Parker Bestobell's unique independent bonnet and flange design, eliminating leakage through the flange gasket.

The Stainless Steel non-extended stem globe valve has a bolted bonnet, integral cone seat and renewable PTFE/PCTFE seal, complete with Stainless Steel internals. Available with various ends, the valve is of the cone seat design for drop tight shut off. The bolted bonnet allows easy maintenance, even in confined spaces.

All valves are degreased for oxygen duty, assembled in clean room conditions and pressure tested prior to dispatch.

## Maximum Working Pressure (MWP)

Subject to end connections

Up to 50 bar (725 psi) at -196°C to +65°C

## Features

- Unique Parker Bestobell loose flange bolted bonnet design allows for thermal expansion and contraction and eliminates leakage at the bonnet gasket
- PTFE/PCTFE seal to ensure tight shut off at all times
- Designed and engineered specifically for cryogenic service
- Anti-blowout stem and one-piece high strength design for operator safety
- Long life, low torque stem thread
- Lightweight ergonomic aluminium handwheel
- Revolving disc ensures non-rotating seat contact for an extended leak free life
- Full bore
- Fast/easy maintenance of PTFE/PCTFE components
- Long life spring loaded gland packing

## Technical

- Designed and engineered for use with Group 1 gases.
- Designed and manufactured in accordance with ASTM B31.1, BS EN 1626 and BS ISO 21011
- Optional full material traceability backed by BS EN 10204 3.1/3.2 certification.

CE Marked according to the Pressure Equipment Directive



DN15 Stainless Steel Globe Valve – Non-Extended Stem with Butt Weld Ends



DN15 Socket Ends



DN15 Socket Ends Sectioned

## Materials

	<b>Stainless Steel</b>
1. Body	Stainless Steel ASTM A351 CF8M
2. Cover	Stainless Steel BS EN 10088-3 1.4301
3. Bonnet Flange	Stainless Steel ASTM A351 CF8M
4. Disc	HT Brass BS EN 12164 CW721R
5. Stem	Stainless Steel BS EN 10088-3 1.4401
6. Gasket Bonnet	Sigma 511
7. Gland Packing	Virgin PTFE
8. Fasteners	Stainless Steel BS6105 A2/A4 Gr.70
9. Seal	Virgin PTFE/PCTFE

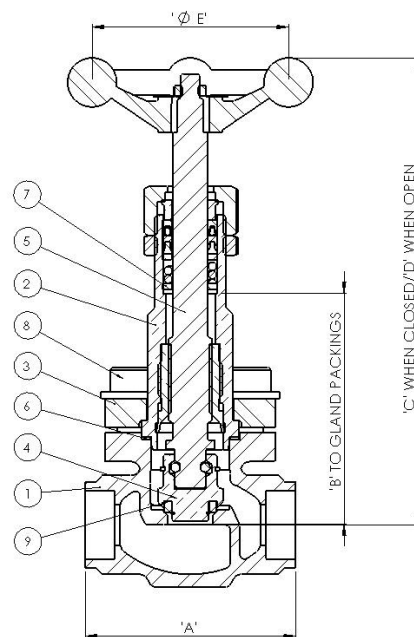

## Specifications

### Butt Weld Ends

Size	Unit	DN6 1/4"	DN10 3/8"	DN15 1/2"	DN20 3/4"	DN25 1"	DN40 1 1/2"	DN50 2"
A	mm	68	68	68	92	92	121	146
B	mm	80	80	80	90	90	110	140
C: Closed	mm	150	150	150	170	170	190	200
D: Open	mm	160	160	160	180	180	200	237
E	mm	80	80	80	101	101	121	144
Cv	US GPM	3.6	3.6	3.6	13.2	13.2	26.5	43
Weight	kg	1.3	1.3	1.3	2	2	4	7

### Flanged Ends (Class 300)

Size	Unit	DN6 1/4"	DN10 3/8"	DN15 1/2"	DN20 3/4"	DN25 1"	DN40 1 1/2"	DN50 2"
F	mm	130	130	130	160	160	200	230
G	mm	95	95	95	124	124	155	165
Flange Thickness	mm	14	14	14	18	18	21	22
Weight	kg	2.8	2.8	2.8	5.3	5.3	9.6	13.8

Class 150 available on request.

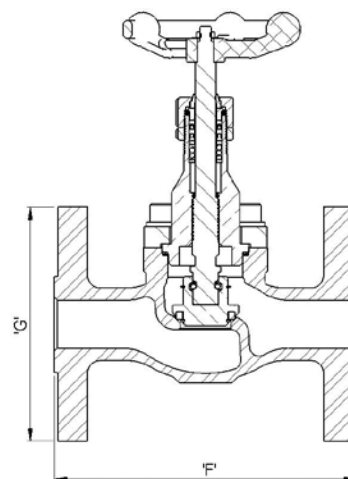

## How to Order

The correct part number is easily derived from the following number sequence

<b>CNT</b>	<b>10</b>	<b>B1</b>	<b>C1</b>	<b>C</b>
Series	Valve Size Diameter Nominal (DN)	Connection Type	Stem Type	Seat
<b>CNT</b> Cryogenic Globe Stainless Steel	<b>10</b> DN6	<b>B1</b> Butt Weld Schedule 10 <b>SN</b> Socket Weld <b>FA</b> Flange Class 150 <b>FC</b> Flange Class 300	Bolted Bonnet - Non-Extended Stem	<b>C</b> Cone
	<b>20</b> DN10			
	<b>30</b> DN15			
	<b>40</b> DN20			
	<b>50</b> DN25			
	<b>70</b> DN40			
	<b>80</b> DN50			

Please contact us for other options.

# Cryogenic Actuated Globe Valve

## Pneumatically Actuated Globe Valve

DN15 - DN150 (1/2" – 6")

The Parker Bestobell on/off and control valves are fitted with a pneumatic diaphragm type actuator.

The actuator uses compressed air to open and a spring to close. Double actuation (i.e. actuated opening and closing) is available upon request.

The range is available with either Butt Weld, Socket Ends or flanged options.

All valves are degreased for oxygen duty, assembled in clean room conditions and pressure tested prior to dispatch.

### Maximum Working Pressure (MWP)

(Subject to End Connections/Actuator)

Up to 50 bar (725 psi) at -196°C to + 65°C

### Features

- Full range of Class 150 Stainless Steel extended globe valves.
- Class 300 available for sizes up to DN100
- Independent bonnet and flange design
- Full Bore
- Throttling and On/Off functions available

### Technical

- Designed and engineered for use with Group 1 gases.
- Full material traceability backed by BS EN 10204 3.1/3.2 certification.
- Available in Butt Weld (ANSI B16.25), Socket Weld and Flange (ANSI B16.5) connections.

CE Marked according to the Pressure Equipment Directive

### Materials

	Stainless Steel
1. Body	Stainless Steel ASTM A351 CF8M
2. Cover	Stainless Steel BS EN 10088-3 1.4301
3. Bonnet Flange	Stainless Steel ASTM A351 CF8M
4. Disc	Stainless Steel BS EN 10088-3 1.4401
5. Seal	PTFE TF7196
6. Gasket Bonnet	Sigma 511
7. Gland Packing	Virgin PTFE
8. Extension Tube	Stainless Steel ASTM A312 TP316L
9. Stem	Stainless Steel BS EN 10088-3 1.4401
10. Fasteners	Stainless Steel BS6105 A2/A4 .Gr.70

\*Bronze body available on request



DN25 Pneumatically Actuated Globe Valve with Butt Weld Ends



DN50 Flanged Ends



DN80 Socket Ends

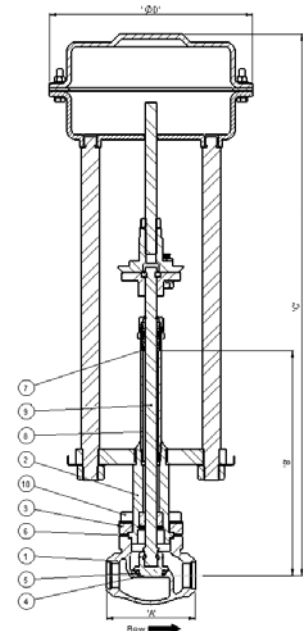

## Specifications

### Butt Weld Ends

Size	Unit	DN15 ½"	DN25 1"	DN40 1½"	DN50 2"	DN65 2½"	DN80 3"	DN100 4"	DN150 6"
A	mm	68	92	121	146	178	178	292	406
B	mm	300	300	300	300	300	300	400	600
C	mm	480	620	637	647	662	682	862	1120
D	mm	162	210	310	310	310	310	415	512
Weight	kg	12	12	40	43	54	60	120	195
Cv	US GPM	3.6	13.2	26.5	43	75	108	198	400

### Flanged Ends

Size	Unit	Class 300					Class 150		
		DN15 ½"	DN25 1"	DN40 1½"	DN50 2"	DN65 2½"	DN80 3"	DN100 4"	DN150 6"
F	mm	130	160	200	230	290	310	350	406
G	mm	95	124	155	165	191	210	254	279
Flange Thickness	mm	14	18	21	22	25	28	32	25
Weight	kg	14	15	46	50	62	72	140	210

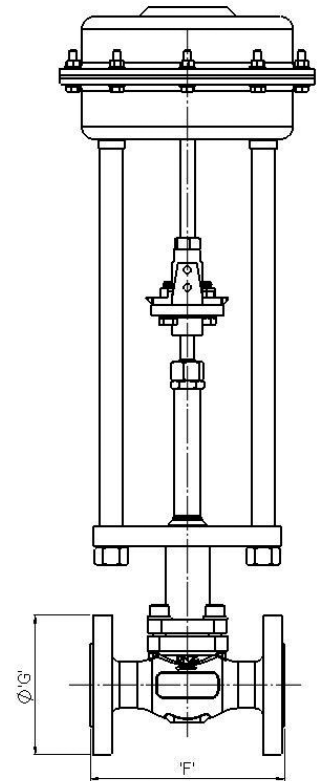

### How to Order

Part Number	Valve Size - Diameter Nominal (DN)	Connection Type	Stem Length (mm)	Maximum Working Pressure (bar)
CNT30B1D6CPA	DN15	Butt Weld Schedule 10	300	50
CNT30SNED6CPA		Socket Weld		
CNT30FCD6CPA		Flange Class 300		
CNT50B1D6CPA	DN25	Butt Weld Schedule 10	300	50
CNT50SNED6CPA		Socket Weld		
CNT50FCD6CPA		Flange Class 300		
CNT70B1D6CPA50	DN40	Butt Weld Schedule 10	300	50
CNT70SNED6CPA50		Socket Weld		
CNT70FCD6CPA50		Flange Class 300		
CNT80B1D6CPA	DN50	Butt Weld Schedule 10	300	40
CNT80SNED6CPA		Socket Weld		
CNT80FCD6CPA		Flange Class 300		
CNT90B1D6CPA	DN65	Butt Weld Schedule 10	300	16
CNT90SNED6CPA		Socket Weld		
CNT90FCD6CPA		Flange Class 300		
CNTA0B1D4CPA	DN80	Butt Weld Schedule 10	300	16
CNTA0SNED4CPA		Socket Weld		
CNTA0FCD4CPA		Flange Class 300		
CNTB0B1D7CPA	DN100	Butt Weld Schedule 10	400	16
CNTB0SNED7CPA		Socket Weld		
CNTB0FAD7CPA		Flange Class 150		
CNTD0B1D9CPA	DN150	Butt Weld Schedule 10	700	16
CNTD0FAD9CPA		Flange Class 150		

Please contact us for other options.

# Cryogenic Manifold Fill Assemblies

## Stainless Steel

### DN25 & DN40 (1" & 1½")

The Parker Bestobell cryogenic main fill valve manifold is specifically designed for cryogenic static storage tanks to replace the traditional gang of valves linked together with piping and a large amount of welding and brazing.

It is the joining together of four valves: top fill, bottom fill, check valve and drain valve. It is available in two sizes 25mm (1") and 40mm (1½").

The design makes it a simple valve to operate from the user perspective. The Manifold can be supplied with various inlet connections to suit customer requirements.

Located within the valve is a spring to close check valve to prevent back wash of media at the end of the filling cycle. A drain valve is fitted to release any trapped media in the fill block. A warm-up leg is also included for the connection of a thermal relief valve.

The unit is supplied ready to be fitted to the tank, with pipe specifications supplied by the customer.



DN40 Stainless Steel Manifold Fill Assembly

### Maximum Working Pressure (MWP)

Subject to end connections

Up to 50 bar (725 psi) at -196°C to +65°C  
(extended stem)

### Features

- A one piece body reduces the number of potential leak paths and simplifies the piping system
- The unique internal characteristics reduces the pressure drop and vessel filling time
- Complete valve assembly reduces the tank build time
- Check valve for additional safety
- Self-draining strainer prevents debris entering the system
- Bolted bonnet headworks allow for easy maintenance

### Technical

- Designed and engineered for use with Group 1 gases.
- Designed and manufactured in accordance with ASTM B31.1, BS EN 1626 and BS ISO 21011
- Optional full material traceability backed by BS EN 10204 3.1/3.2 certification.
- Manual operated inside screw globe valves, size range DN25 and DN40.
- Available with stainless stubs.

CE Marked according to the Pressure Equipment Directive



DN40 Stainless Steel Manifold Fill Assembly

## Materials

	<b>Stainless Steel</b>
1. Body	Stainless Steel ASTM A351 CF8M
2. Bonnet	Stainless Steel BS EN 10088-3 1.4401
3. Tube, Extension	Stainless Steel ASTM A312 TP 304L
4. Stem	Stainless Steel BS EN 10088-3 1.4401
5. Handwheel	Aluminium
6. Disc	HT Brass BS EN 12164 CW721R
7. Gasket	Sigma 511
8. Seal	PCTFE
9. Gland Packing	Virgin PTFE Sigma 511
10. Fasteners	Stainless Steel BS6105 A2/A4 Gr.70
11. Down Pipe	Copper ASTM B88
12. Central Body	Gunmetal BS EN 1982 CC491K
13. Strainer	Brass
14. Disc	HT Brass BS EN 12164 CW721R
15. Spring	PHOS BRZ BS EN 12163 CW451K

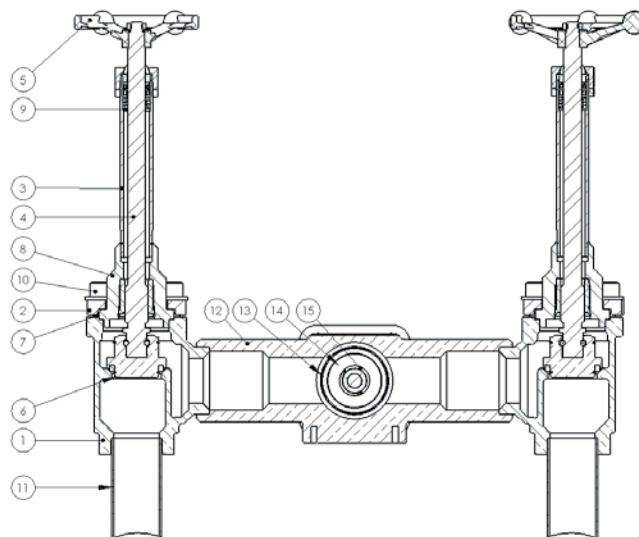

## Specifications

### Stainless Steel Stubs

Size	Unit	DN40
A	mm	359
B	mm	137 Schedule 10 Stainless Steel Stubs (533 B88)
C	mm	230
D	mm	121
E	mm	90
F	mm	292

### Long Centre Type Stainless Steel

Size	Unit	DN25	DN40
A	mm	295	301
B	mm	85	85
C	mm	230	230
D	mm	101	121
E	mm	90	90
F	mm	118	118
		Socket End To Suit 1" NB Schedule 10	Socket End To Suit 1½" NB Schedule 10

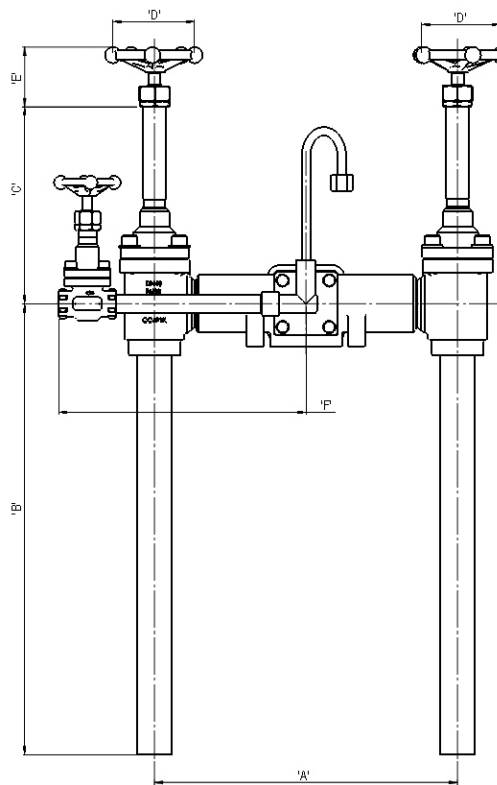

## How to Order

Part Number	Valve Size - Diameter Nominal (DN)	Options
CTS50PPD63CAL	DN25	With check function
CTS50PPD63CIN		Without check function
CTS70PPD63CAL	DN40	With check function
CTS70PPD63CIN		Without check function

All dimensions / weights are approximate  
Please contact us for other options.

# Cryogenic Manifold Fill Assemblies

Bronze

DN40 (1½")

The Parker Bestobell cryogenic main fill valve manifold is specifically designed for cryogenic static storage tanks to replace the traditional gang of valves linked together with piping and a large amount of welding and brazing.

It is the joining together of four valves: top fill, bottom fill, check valve and drain valve.

The design makes it a simple valve to operate from the user perspective. The Manifold can be supplied with various inlet connections to suit customer requirements.

Located within the valve is a spring to close check valve to prevent back wash of media at the end of the filling cycle. A drain valve is fitted to release any trapped media in the fill block. A warm-up leg is also included for the connection of a thermal relief valve.

The unit is supplied ready to be fitted to the tank, with pipe specifications supplied by the customer.



DN40 Bronze Manifold Fill Assembly

## Maximum Working Pressure (MWP)

Subject to end connections

Up to 50 bar (725 psi) at -196°C to +65°C  
(extended stem)

## Features

- A one piece body reduces the number of potential leak paths and simplifies the piping system
- The unique internal characteristics reduces the pressure drop and vessel filling time
- Complete valve assembly reduces the tank build time
- Check valve for additional safety
- Self-draining strainer prevents debris entering the system
- Bolted bonnet headworks allow for easy maintenance

## Technical

- Designed and engineered for use with Group 1 gases.
- Designed and manufactured in accordance with ASTM B31.1, BS EN 1626 and BS ISO 21011
- Optional full material traceability backed by BS EN 10204 3.1/3.2 certification.
- Manual operated inside screw globe valves.
- Available with copper and Stainless Steel stubs.

CE Marked according to the Pressure Equipment Directive



DN40 Bronze Manifold Fill Assembly



DN40 with Short Centre Manifold Fill Assembly



## Materials

	<b>Bronze</b>
1. Body	Gunmetal BS EN 1982 CC491K
2. Bonnet	Gunmetal BS EN 1982 CC491K
3. Tube, Extension	Stainless Steel ASTM A312 TP 304L
4. Stem	Stainless Steel BS EN 10088-3 1.4401
5. Handwheel	Aluminium
6. Disc	HT Brass BS EN 12164 CW721R
7. Gasket	Sigma 511
8. Seal	PCTFE
9. Gland Packing	Virgin PTFE Sigma 511
10. Fasteners	Stainless Steel BS6105 A2/A4 Gr.70
11. Down Pipe	Stainless Steel ASTM A312 TP304L
12. Central Body	Gunmetal BS EN 1982 CC491K
13. Strainer	Brass
14. Disc	HT Brass BS EN 12164 CW721R
15. Spring	PHOS BRZ BS EN 12163 CW451K

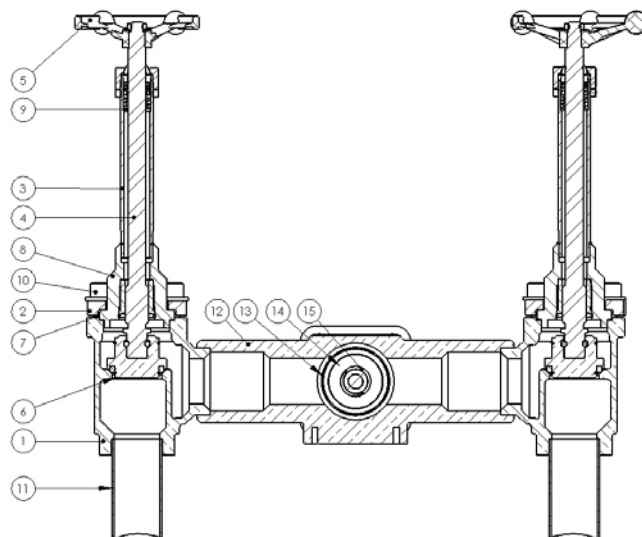

## Specifications

### Short Centre Type Bronze Casting

Size	Unit	DN40
A	mm	121
B	mm	248
C	mm	406
D	mm	146
E	mm	483
F	mm	502
G	mm	381
H	mm	102
I	mm	305
J	mm	152
K	mm	400
Cv	US GPM	26.5
Weight	kg	15

### Long Centre Type Bronze Casting

Size	Unit	DN40
A	mm	301
B	mm	85
C	mm	230
D	Dia mm	121
E	mm	90
F	mm	118
G	Socket End To Suit 1½" NB Schedule 10	

### Short Centre Type Bronze Casting

Size	Unit	DN40
A	mm	120
B	mm	248
C	mm	400
D	mm	121
E	mm	80
F	mm	300
G	1½" NB Schedule 10	
H	mm	112
J	mm	156
Cv	US GPM	26.5
Weight	kg	15

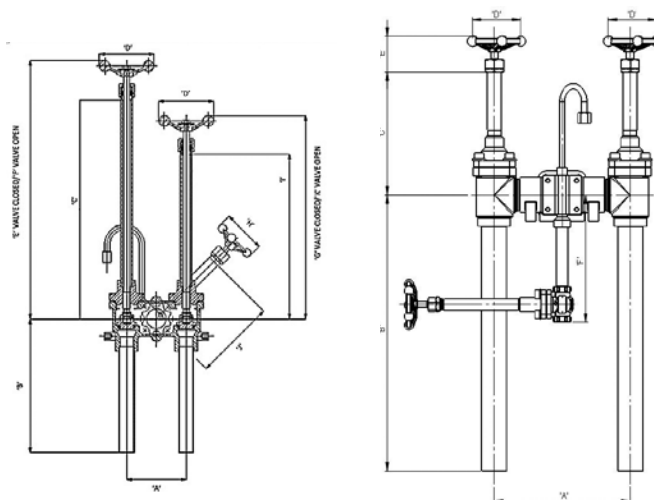

## How to Order

Part Number	Valve Size - Diameter Nominal (DN)	Stubs material	Options
CTB70F1LLET00	DN40	Stainless Steel	Without redundant valves
CTB70F1LLPR010		Copper	Without redundant valves
CTB70F1LLPR020		Copper	With redundant valves

All dimensions / weights are approximate  
Please contact us for other options.

# Cryogenic Stainless Steel Manual Gate Valve

Bolted Bonnet - Extended Stem  
DN40 - DN100 (1½" - 4")

The Stainless Steel uni-directional extended stem gate valve has a bolted bonnet, integral soft seat and bronze internals. Available with Butt Weld ends, the valve has a wedge seat design for tight shut off designed to seal on downstream seat only in order to prevent liquid lock. The bolted bonnet allows for simple site maintenance with easy access to the serviceable parts of the valve.

All valves are degreased for oxygen duty, assembled in clean room conditions and pressure tested prior to dispatch.

## Maximum Working Pressure (MWP)

Subject to end connections

Up to 40 bar (580 psi) at -196°C to +65°C

## Features

- Replaceable body seat that is part of the headwork assembly (excluding DN40)
- Precision investment cast body - smooth surface finish
- Lapped seat and PTFE seal ensure a tight shut off at all time
- Lightweight design gives excellent thermal characteristics
- Anti-blow out stem and one-piece high strength stem design for operator safety
- Long life, low torque stem thread
- Screwed and welded high strength extension tube and bonnet joints
- Lightweight ergonomic handwheel
- Quick removal of headworks allows fast/easy maintenance

## Technical

- Designed and engineered for use with Group 1 gases.
- Designed and manufactured in accordance with ASTM B31.1, BS EN 1626 and BS ISO 21011
- Optional full material traceability backed by BS EN 10204 3.1/3.2 certification.

CE Marked according to the Pressure Equipment Directive

Please contact us for other options.



DN40 Stainless Steel Gate Valve with Butt Weld Ends



DN50 Butt Weld Ends



DN80 Butt Weld Ends

## Materials

	Stainless Steel
1. Body	Stainless Steel ASTM A351 CF8M
2. Cover	Stainless Steel ASTM A351 CF8M
3. Stem	Stainless Steel BS EN 10088-3 1.4401
4. Wedge	Stainless Steel ASTM A351 CF8M
5. Disc	Phosphor Bronze
6. Disc/Seat Seal	Virgin PTFE
7. Packing Assembly	HT Brass/Virgin PTFE
8. Extension Tube	Stainless Steel ASTM A312 TP304L
9. Handwheel	Aluminium
10. Seat	Stainless Steel BS EN 10088-3 1.4401
11. Bonnet Gasket	Sigma 511
12. Fasteners	Stainless Steel BS6105 A2/A4 Gr.70

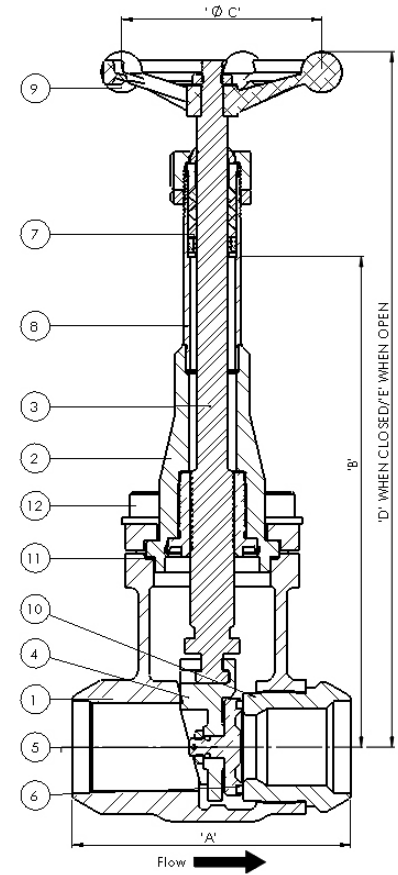

## Specifications

Size	Unit	DN40 1½"	DN50 2"	DN65 2½"	DN80 3"	DN100 4"
A	mm	130	140	150	150	229
B	mm	230	300	300	400	400
C	mm	102	146	146	146	146
D	mm	326	396	389	496	496
E	mm	363	456	464	586	586
Cv	US GPM	132	240	380	560	560
Weight	kg	5.3	10.4	12.9	18.2	20.5

## How to Order

Part Number	Valve Size Diameter Nominal (DN)	Connection Type	Stem Length (mm)
CMC70B1D3S00	DN40	Butt Weld Schedule 10	230
CMC70STED3S00		Socket Weld	
CMC80B1D6S00	DN50	Butt Weld Schedule 10	300
CMC80STED6S00		Socket Weld	
CMC90B1D4S00	DN65	Butt Weld Schedule 10	300
CMC90STED4S00		Socket Weld	
CMCA0B1D7S00	DN80	Butt Weld Schedule 10	400
CMCA0STED7S00		Socket Weld	
CMCB0B1D7S00	DN100	Butt Weld Schedule 10	400
CMCB0STED7S00		Socket Weld	

Please contact us for other options.

# Cryogenic Stainless Steel Actuated Gate Valve

Bolted Bonnet - Pneumatic Tyre Design  
Fail to Close

DN40 - DN100 (1½" – 4")

The Stainless Steel uni-directional cryogenic emergency shut off valve has a bolted bonnet and integral pneumatic actuator. The valve is of fail to close design with automatic operation. The valve is equipped with a manual override system in case air has been lost and an emergency discharge is required. The valve has an integral seat and bronze internals. Available with Butt Weld ends, the valve has a wedge seat design for tight shut off designed to seal on downstream seat only in order to prevent liquid lock. The bolted bonnet allows for simple site maintenance with easy access to the serviceable parts of the valve.

All valves are degreased for oxygen duty, assembled in clean room conditions and pressure tested prior to dispatch.

## Maximum Working Pressure (MWP)

Subject to end connections

Up to 40 bar (580 psi) at -196°C to +65°C

## Features

- Replaceable body seat that is part of the headwork assembly (excluding DN40)
- Precision investment cast body - smooth surface finish
- Lapped seat and PTFE seal ensure a tight shut off at all time
- Lightweight design gives excellent thermal characteristics
- Anti-blow out stem and one-piece high strength stem design for operator safety
- Screwed and welded high strength extension tube and bonnet joints
- Quick removal of headworks allows fast/easy maintenance
- 316 Stainless Steel construction with bronze internal components
- Manual override hand wheel available on request

## Technical

- Designed and engineered for use with Group 1 gases.
- Designed and manufactured in accordance with ASTM B31.1, BS EN 1626 and BS ISO 21011
- Optional full material traceability backed by BS EN 10204 3.1/3.2 certification.

CE Marked according to the Pressure Equipment Directive



DN80 Actuated Gate Valve with Butt Weld Ends without guard



DN80 Actuated Gate Valve with Butt Weld Ends with guard



DN40 Butt Weld Ends



DN50 Socket Ends

## Materials

	<b>Stainless Steel</b>
1. Body	Stainless Steel ASTM A351 CF8M
2. Cover	Stainless Steel ASTM A351 CF8M
3. Stem	Stainless Steel BS EN 10088-3 1.4401
4. Wedge	Stainless Steel ASTM A351 CF8M
5. Disc	Phosphor Bronze
6. Disc/Seat Seal	Virgin PTFE
7. Extension Tube	Stainless Steel ASTM A312 TP304L
8. Seat	Stainless Steel ASTM A312 TP304L
9. Gasket	Sigma 511
10. Fasteners	Stainless Steel BS6105 A2/A4 Gr.70

## Specifications

Size	Unit	DN40 1½"	DN50 2"	DN65 2½"	DN80 3"	DN100 4"
A	mm	130	140	150	150	229
B	mm	450	495	502	535	535
C	mm	490	540	567	615	615
D	mm	165	240	240	240	240
Cv	US GPM	132	240	380	560	560
Weight	kg	13	19	21.7	27.1	30

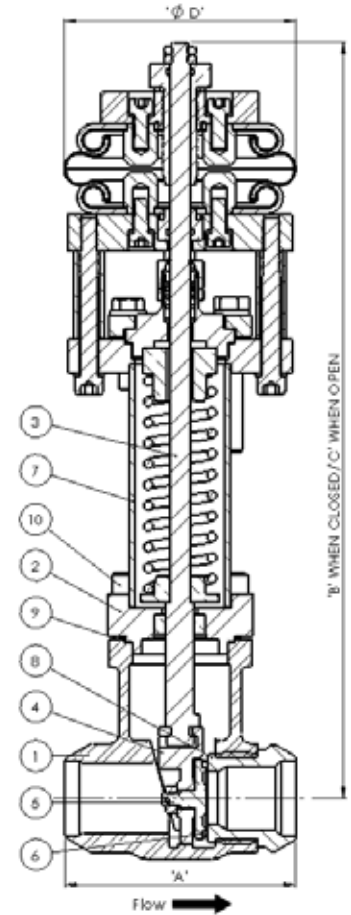

## How to Order

Part Number	Valve Size Diameter Nominal (DN)	Connection Type	Stem Length (mm)	Options
CMD70B1D6STY	DN40	Butt Weld Schedule 10	300	Without guard
CMD70STED6STY		Socket Weld		
CMD70B1D6STC		Butt Weld Schedule 10		With guard
CMD70STED6STC		Socket Weld		
CMD80B1D8STY	DN50	Butt Weld Schedule 10	500	Without guard
CMD80STED8STY		Socket Weld		
CMD80B1D8STC		Butt Weld Schedule 10		With guard
CMD80STED8STC		Socket Weld		
CMD90B1D8STY	DN65	Butt Weld Schedule 10	500	Without guard
CMD90STED8STY		Socket Weld		
CMD90B1D8STC		Butt Weld Schedule 10		With guard
CMD90STED8STC		Socket Weld		
CMDA0B1D8STY	DN80	Butt Weld Schedule 10	500	Without guard
CMDA0STED8STY		Socket Weld		
CMDA0B1D8STC		Butt Weld Schedule 10		With guard
CMDA0STED8STC		Socket Weld		
CMDB0B1D8STY	DN100	Butt Weld Schedule 10	500	Without guard
CMDB0STED8STY		Socket Weld		
CMDB0B1D8STC		Butt Weld Schedule 10		With guard
CMDB0STED8STC		Socket Weld		

Please contact us for other options.

# Cryogenic Bronze Ball Valve

Reduced Bore

DN15- DN50 (1/2" - 2")

This Bronze uni-directional ball valve has been designed specifically for cryogenic applications. It is available with NPT or BSP threaded ends.

The flow co-efficient (CV) allows full flow of media from filling stations and portable delivery systems therefore no delay in filling time.

Other variations include:

- Stainless Steel Version
- Actuated
- Full Bore

All valves are degreased for oxygen duty, assembled in clean room conditions and pressure tested prior to dispatch.

## Maximum Working Pressure (MWP)

Subject to end connections

Up to 50 bar (725 psi) at -196°C to +65°C

## Features

- Spring loaded gland seal giving low torque levels under both ambient and cryogenic conditions
- One piece, anti-blow-out stem
- Relief hole to prevent trapping of liquefied gases
- Designed to prevent incorrect, and hence dangerous, re-assembly after stripping for maintenance
- Removable centre section designed to industry standard dimensions, allowing interchangeability in existing installations
- Valves can be supplied with actuators fitted allowing fast, remote automatic operation
- Long life spring loaded gland packing

## Technical

- Designed and engineered for use with Group 1 gases.
- Designed and manufactured in accordance with ASTM B31.1, BS EN 1626 and BS ISO 21011
- Optional full material traceability backed by BS EN 10204 3.1/3.2 certification.

CE Marked according to the Pressure Equipment Directive



DN50 Bronze Ball Valve with NPT Threaded Ends



DN15 NPT Threaded Ends



DN25 NPT Threaded Ends

## Materials

	<b>Bronze</b>
1. Body	Gunmetal BS EN 1982 CC491K
2. End Adaptors	Gunmetal BS EN 1982 CC491K
3. Gland Housing	Stainless Steel ASTM A351 CF8M
4. Lever	Stainless Steel ASTM A351 CF8M
5. Extension Tube	Stainless Steel ASTM A269 TP304L
6. Stem	Stainless Steel BS EN 10088-3 1.4401
7. Ball	Brass BS EN 12164 CW614N
8. Ball Seal	Hostafлон
9. End Adaptor Seal	Virgin PTFE
10. Fasteners	Stainless Steel BS6105 A2/A4 Gr.70
11. Gland Packings	Virgin PTFE

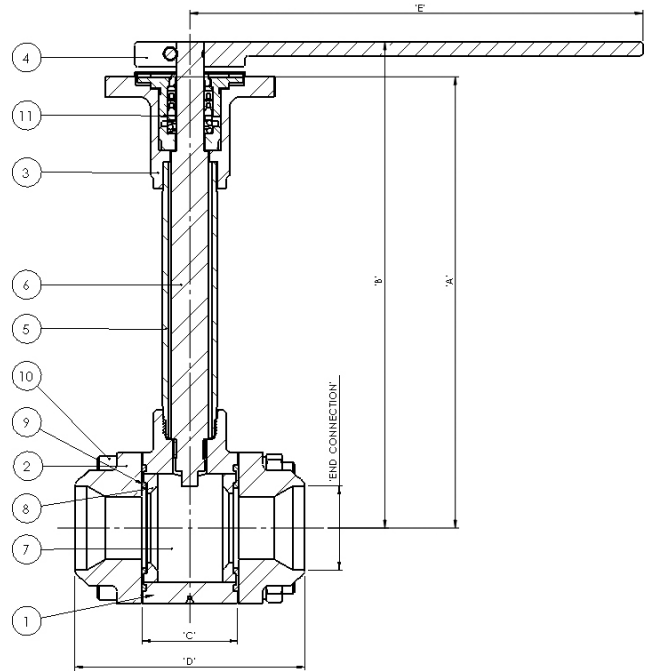

## Specifications

Size	Valve Size		Reduced Bore Size		Dimension						Torque		CV (US GPM)	Weight (kg)
	mm	in	mm	in	A	B	C	D	E	P.C.D	Nm	lbft		
DN15	15	½	11	¾	230	250	21	67	190	50	10	7	9	2
DN25	25	1	20	¾	230	250	32	96	190	60	23	17	30	3
DN40	40	1½	32	1¼	230	250	49	117	230	80	40	30	90	5
DN50	50	2	37	1½	230	250	56	129	230	100	62	46	138	7

## How to Order

Part Number	Valve Size Diameter Nominal (DN)	Connection Type	Stem Length (mm)	Option
CZFR30GTAE4BND	DN15	BSP-PL	230	Without stubs
CZFR30GTEE4BND		NPT		
CZFR50GTAE4BND	DN25	BSP-PL	230	Without stubs
CZFR50GTEE4BND		NPT		
CZFR70GTAE4BND	DN40	BSP-PL	230	Without stubs
CZFR70GTEE4BND		NPT		
CZFR80GTAE4BND	DN50	BSP-PL	230	Without stubs
CZFR80GTEE4BND		NPT		

Please contact us for other options.

# Cryogenic Stainless Steel Ball Valve

Reduced Bore

DN15 - DN50 (1/2" - 2")

This Stainless Steel uni-directional ball valve has been designed specifically for cryogenic applications. It is available with Socket Weld and Butt Weld ends.

The flow co-efficient (CV) allows full flow of media from filling stations and portable delivery systems therefore no delay in filling time.

Other variations include:

- Bronze Version
- Actuated
- Full Bore

All valves are degreased for oxygen duty, assembled in clean room conditions and pressure tested prior to dispatch.

## Maximum Working Pressure (MWP)

Subject to end connections

Up to 50 bar (725 psi) at -196°C to +65°C

## Features

- Spring loaded gland seal giving low torque levels under both ambient and cryogenic conditions
- Precision investment cast body - smooth surface finish
- Once piece, anti-blow-out stem
- Relief hole to prevent trapping of liquefied gases
- Designed to prevent incorrect, and hence dangerous, re-assembly after stripping for maintenance
- Removable centre section designed to industry standard dimensions, allowing interchangeability in existing installations
- Valves can be supplied with actuators fitted allowing fast, remote automatic operation
- Long life spring loaded gland packing

## Technical

- Designed and engineered for use with Group 1 gases.
- Designed and manufactured in accordance with ASTM B31.1, BS EN 1626 and BS ISO 21011
- Optional full material traceability backed by BS EN 10204 3.1/3.2 certification.

CE Marked according to the Pressure Equipment Directive



DN40 Stainless Steel Ball Valve with Butt Weld Ends



DN40 Socket Ends



## Materials

	Stainless Steel
1. Body	Stainless Steel ASTM A351 CF8M
2. End Adaptors	Stainless Steel ASTM A351 CF8M
3. Gland Housing	Stainless Steel ASTM A351 CF8M
4. Lever	Stainless Steel ASTM A351 CF8M
5. Extension Tube	Stainless Steel ASTM A312 TP304L
6. Stem	Stainless Steel BS EN 10088-3 1.4401
7. Ball	Stainless Steel 316 S31 BS970
8. Ball Seal	Hostaflon
9. End Adaptor Seal	Virgin PTFE
10. Fasteners	Stainless Steel BS6105 A2/A4 Gr.70
11. Gland Packings	Virgin PTFE

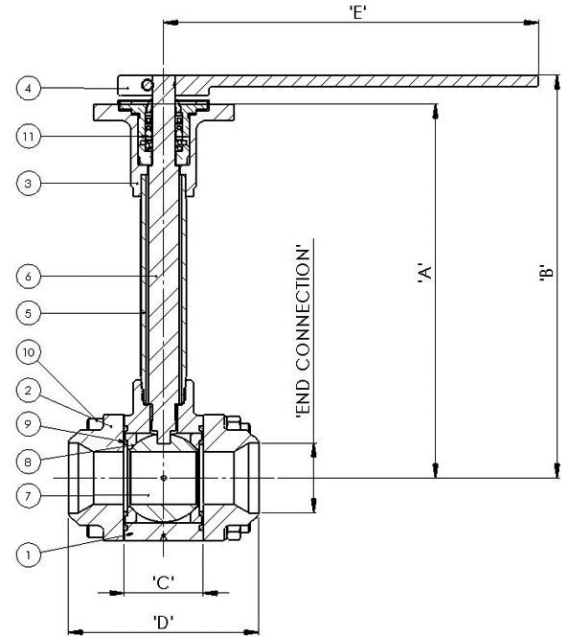

## Specifications

Size	Valve Size		Reduced Bore Size		Dimension						Torque		CV US GPM	Weight (kg)
	mm	in	mm	in	A	B	C	D	E	P.C.D	Nm	lbft		
DN15	15	½	11	¾	230	250	21	67	190	50	10	7	9	3
DN25	25	1	20	¾	230	250	32	96	190	60	23	17	30	5.5
DN40	40	1½	32	1¼	230	250	49	117	230	80	40	30	90	7
DN50	50	2	37	1½	230	250	56	129	230	100	62	46	138	7.2

## How to Order

Part Number	Valve Size Diameter Nominal (DN)	Connection Type	Stem Length (mm)	Option
CZFR30SB1E4S00	DN15	Butt Weld Schedule 10	230	Without stubs
CZFR30SSNE4S00		Socket Weld		
CZFR50SB1E4S00	DN25	Butt Weld Schedule 10	230	Without stubs
CZFR50SSNE4S00		Socket Weld		
CZFR70SB1E4S00	DN40	Butt Weld Schedule 10	230	Without stubs
CZFR70SSNE4S00		Socket Weld		
CZFR80SB1E4S00	DN50	Butt Weld Schedule 10	230	Without stubs
CZFR80SSNE4S00		Socket Weld		

Please contact us for other options.

# Cryogenic Wafer Ball Valve

Reduced Bore  
DN80 (3")

This uni-directional wafer type ball valve has been designed specifically for cryogenic applications. It is available with Butt Weld ends (for Stainless Steel) and threaded ends (for Bronze).

The flow co-efficient (CV) allows full flow of media from filling stations and portable delivery systems therefore no delay in filling time.

All valves are degreased for oxygen duty, assembled in clean room conditions and pressure tested prior to dispatch.

## Maximum Working Pressure (MWP)

Subject to end connections

Up to 34 bar (500 psi) at -196°C to +65°C

## Features

- Precision investment cast body – smooth surface finish (for Stainless Steel Valves)
- One piece, anti-blowout stem
- Relief hole to prevent trapping of liquefied gases
- Designed to prevent incorrect, and hence dangerous, re-assembly after stripping for maintenance
- Removable centre section wafer pattern designed to suit industrial standard dimensions, allowing interchangeability in existing installations
- Valves can be supplied with pneumatic actuators fitted allowing fast, remote or automatic operation



Stainless Steel DN80 Wafer Ball Valve with Butt Weld Ends

## Technical

- Designed and engineered for use with Group 1 gases.
- Designed and manufactured in accordance with ASTM B31.1, BS EN 1626 and BS ISO 21011
- Optional full material traceability backed by BS EN 10204 3.1/3.2 certification.

CE Marked according to the Pressure Equipment Directive



Pneumatically Actuated



Sectioned View



Centre Section

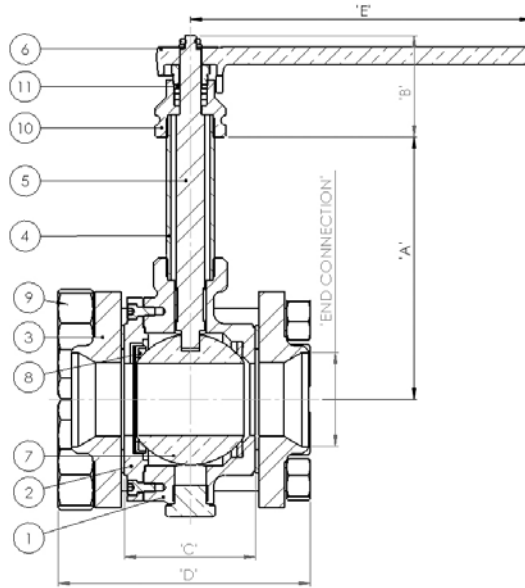

## Materials

	Stainless Steel	Bronze
1. Body	Stainless Steel ASTM A351 CF8M	Gunmetal BS EN 1982 CC491K
2. End Adaptors	Stainless Steel ASTM A351 CF8M	Gunmetal BS EN 1982 CC491K
3. Gland Housing	Stainless Steel ASTM A351 CF8M	Stainless Steel ASTM A351 CF8M
4. Extension Tube	Stainless Steel ASTM A312 TP304L	Stainless Steel ASTM A312 TP304L
5. Stem	Stainless Steel BS EN 10088-3 1.4401	Stainless Steel BS EN 10088-3 1.4401
6. Lever	Stainless Steel ASTM A351 CF8M	Stainless Steel ASTM A351 CF8M
7. Ball	Stainless Steel Series 300	Stainless Steel Series 300 / Brass
8. Retainer	HT Brass BS EN 12164 CW721R	HT Brass BS EN 12164 CW721R
9. Fasteners	Stainless Steel BS6105 A2/A4 Gr. 70	Stainless Steel BS6105 A2/A4 Gr. A4
10. Packings	Virgin PTFE	Virgin PTFE
11. Seal to Ball	Virgin PTFE	Virgin PTFE

## Specifications

Size	Valve Size		Dimension					Torque		CV US GPM	Weight (kg)
			A	B	C	D	E	Nm	lbft		
	mm	in	mm	mm	mm	mm	mm				
DN80	80	3	230	80	110	215	300	102	75	300	30

## How to Order

Part Number	Valve Size Diameter Nominal (DN)	Connection Type	Stem Length (mm)	Option
CZFRA0GTEE5A00	DN80	NPT	230	Without stubs
CZFRA0GTAE5A00		BSP-PL		
CZFRA0SB1E4S00		Butt Weld Schedule 10		

Please contact us for other options.

# Cryogenic Actuated Bronze Ball Valve

Reduced Bore

DN15 - DN50 (1/2" - 2")

This Bronze uni-directional three-piece ball valve has been designed specifically for cryogenic applications. It is available with threaded ends.

The flow co-efficient (CV) allows full flow of media from filling stations and portable delivery systems therefore no delay in filling time.

All valves are degreased for oxygen duty, assembled in clean room conditions and pressure tested prior to dispatch.

## Maximum Working Pressure (MWP)

Subject to end connections

Up to 50 bar (725 psi) at -196°C to +65°C

## Features

- Spring loaded gland seal giving low torque levels under both ambient and cryogenic conditions
- One piece, anti-blow-out stem
- Relief hole to prevent trapping of liquefied gases
- Designed to prevent incorrect, and hence dangerous, re-assembly after stripping for maintenance
- Removable centre section designed to industry standard dimensions, allowing interchangeability in existing installations

## Technical

- Designed and engineered for use with Group 1 gases.
- Designed and manufactured in accordance with ASTM B31.1, BS EN 1626 and BS ISO 21011
- Optional full material traceability backed by BS EN 10204 3.1/3.2 certification.

CE Marked according to the Pressure Equipment Directive



DN50 Actuated Bronze Ball Valve with NPT Threaded Ends



DN40 Actuated Bronze Ball Valve - Centre Section

## Materials

	<b>Bronze</b>
1. Body	Gunmetal BS EN 1982 CC491K
2. End Adaptors	Gunmetal BS EN 1982 CC491K
3. Extension Tube	Stainless Steel ASTM A312 304L
4. Stem	Stainless Steel BS EN 10088-3 1.4401
5. Ball	Stainless Steel Series 300 / Brass
6. Seal	Virgin PTFE
7. Packings	Virgin PTFE
8. Fasteners	Stainless Steel BS6105 A2/A4 Gr.70

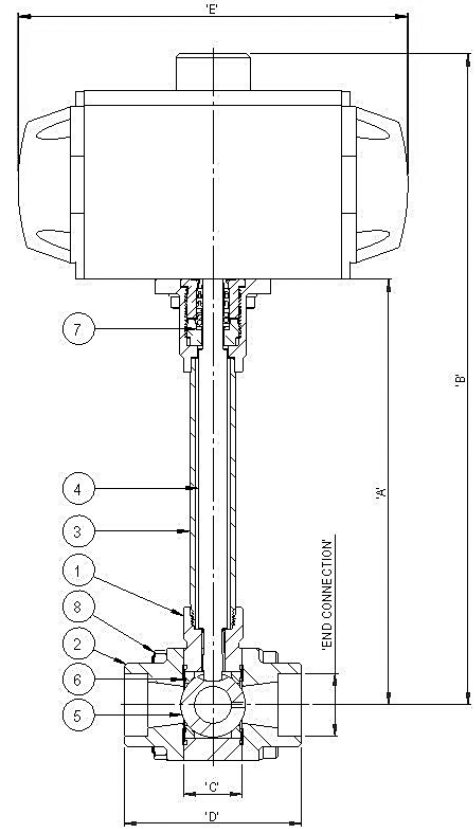

## Specifications

Size	Valve Size		Reduced Bore Size		Dimension						Ball Valve Torque		CV US GPM	Weight (kg)
	mm	in	mm	in	A	B	C	D	E	P.C.D	Nm	lbft		
DN15	15	½	10	¾	230	352	21	67	210	45	10	7	9	4.7
DN25	25	1	20	¾	230	352	32	96	210	63	23	17	30	5.5
DN40	40	1½	30	1¼	230	405	49	117	315	81	40	30	90	15.5
DN50	50	2	40	1½	230	405	56	129	315	95	62	46	138	16

CZFR30GTEE4BAM

## How to Order

Part Number	Valve Size Diameter Nominal (DN)	Connection Type	Stem Length (mm)	Option
CZFR30GTEE4BAM	DN15	NPT	230	Without stubs
CZFR30GTAE4BAM		BSP-PL		
CZFR50GTEE4BAM	DN25	NPT	230	Without stubs
CZFR50GTAE4BAM		BSP-PL		
CZFR70GTEE4BAM	DN40	NPT	230	Without stubs
CZFR70GTAE4BAM		BSP-PL		
CZFR80GTEE4BAM	DN50	NPT	230	Without stubs
CZFR80GTAE4BAM		BSP-PL		

Please contact us for other options.

# Cryogenic Actuated Stainless Steel Ball Valve

Reduced Bore

DN15 - DN50 (1/2" - 2")

This Stainless Steel uni-directional three-piece ball valve has been designed specifically for cryogenic applications. It is available with Socket Weld and Butt Weld ends.

The flow co-efficient (CV) allows full flow of media from filling stations and portable delivery systems therefore no delay in filling time.

All valves are degreased for oxygen duty, assembled in clean room conditions and pressure tested prior to dispatch.

## Maximum Working Pressure (MWP)

Subject to end connections

Up to 50 bar (725 psi) at -196°C to +65°C

## Features

- Spring loaded gland seal giving low torque levels under both ambient and cryogenic conditions
- Precision investment cast body – smooth surface finish
- One piece, anti-blow-out stem
- Relief hole to prevent trapping of liquefied gases
- Designed to prevent incorrect, and hence dangerous, re-assembly after stripping for maintenance
- Removable centre section designed to industry standard dimensions, allowing interchangeability in existing installations

## Technical

- Designed and engineered for use with Group 1 gases.
- Designed and manufactured in accordance with ASTM B31.1, BS EN 1626 and BS ISO 21011
- Optional full material traceability backed by BS EN 10204 3.1/3.2 certification.

CE Marked according to the Pressure Equipment Directive



DN25 Actuated Stainless Steel Ball Valve – Reduced Bore with Butt Weld Ends



DN25 Actuated Stainless Steel Ball Valve - Centre Section

## Materials

	Stainless Steel
1. Body	Stainless Steel ASTM A351 CF8M
2. End Adaptors	Stainless Steel ASTM A351 CF8M
3. Extension Tube	Stainless Steel ASTM A312 TP304L
4. Stem	Stainless Steel BS EN 10088-3 1.4401
5. Ball	Stainless Steel Series 300
6. Seal	Virgin PTFE
7. Packings	Virgin PTFE
8. Fasteners	Stainless Steel BS6105 A2/A4 Gr.70

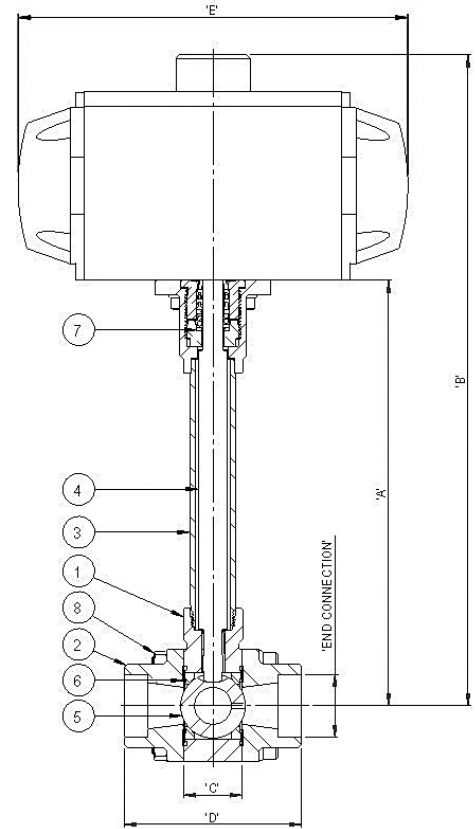

## Specifications

Size	Valve Size		Reduced Bore Size		Dimension						Ball Valve Torque		CV US GPM	Weight (kg)
	mm	in	mm	in	A	B	C	D	E	P.C.D	Nm	lbft		
DN15	15	½	10	¾	230	352	21	67	210	45	10	7	9	4.7
DN25	25	1	20	¾	230	352	32	96	210	63	23	17	30	5.5
DN40	40	1½	30	1¼	230	405	49	117	315	81	40	30	90	15.5
DN50	50	2	40	1½	230	405	56	129	315	95	62	46	138	16

## How to Order

Part Number	Valve Size Diameter Nominal (DN)	Connection Type	Stem Length (mm)	Option
CZFR30SB1E4SAM	DN15	Butt Weld Schedule 10	230	Without stubs
CZFR30SSNE4SAM		Socket Weld		
CZFR50SB1E4SAM	DN25	Butt Weld Schedule 10	230	Without stubs
CZFR50SSNE4SAM		Socket Weld		
CZFR70SB1E4SAM	DN40	Butt Weld Schedule 10	230	Without stubs
CZFR70SSNE4SAM		Socket Weld		
CZFR80SB1E4SAM	DN50	Butt Weld Schedule 10	230	Without stubs
CZFR80SSNE4SAM		Socket Weld		

Please contact us for other options.

# Cryogenic Safety Relief Valve

Bronze

Nozzle 10 - 20 ( $\frac{3}{8}$ " -  $\frac{3}{4}$ " )

A range of high quality Bronze relief valves designed to comply with ISO 4126 (Safety Valves General Requirement), Ad-Merkblatt A2 (Safety Devices against Excess Pressure) and TUV requirements. They are eminently suited to the protection of static and road going cryogenic storage tanks against damaging over pressure.

There are three basic sizes, defined by the throat diameter and each is available with a variety of inlet and outlet connections.

The valve is designed and factory set to lift repeatedly within 2% of the set pressure and to reseal above 92% of set pressure. Spring pre-compression and blow down ring settings are sealed after test to inhibit unauthorized tampering.

Flow rates at 10% above set pressure.

All valves are degreased for oxygen duty, assembled in clean room conditions and pressure tested prior to dispatch.

Each valve is individually set and flow tested and then stamped with the date of manufacture and its own unique serial number prior to dispatch.

## Maximum Working Pressure (MWP)

Subject to end connections

Up to 40 bar (580 psi) at -196°C to + 65°C

## Technical

- Designed and engineered for use with Group 1 gases.
- Designed and manufactured to ISO 4126 (SVGR) ASTM B31.1, BS EN 1626
- Optional full material traceability backed by BS EN 10204 3.1/3.2 certification.

CE Marked according to the Pressure Equipment Directive

## Materials

	Bronze
1. Body	Gunmetal BS EN 1982 CC491K
2. Seat	HT Brass BS EN 12164 CW721R
3. Adjusting Cap	Gunmetal BS EN 1982 CC491K
4. Disc (Nozzle 10)	Brass BS EN 12163 CW712R
Disc (Nozzle 15, 20)	Phosphor Bronze BS EN 12163 CW451R
5. Seal	PTFE TF7196
6. Blow Down Ring	Gunmetal BS EN 1982 CC491K
7. Spring	Stainless Steel 302 S26 BS2056
8. Weather Proof Cap	HT Brass BS EN 12164 CW721R

## Specifications

Size	Unit	DN10	DN15	DN20
A	mm	48	64	64
B	mm	130	133	133
C	mm	60	73	73
Weight	kg	1.5	3	3

## Technical Data

Inlet Orifice Dia (mm)	Set Pressure Range (Bar)	Inlet Sizes (BSP/NPT)	Outlet Sizes (BSP/NPT)
11.4	1.7 - 40	$\frac{1}{2}$ " or $\frac{3}{4}$ "	$\frac{3}{4}$ " or 1"
14	1.7 - 40	$\frac{3}{4}$ " or 1"	1 $\frac{1}{4}$ "
20.50	1.7 - 30	1" or 1 $\frac{1}{4}$ "	1 $\frac{1}{2}$ " or 1 $\frac{1}{4}$ "



Nozzle 15 Bronze Safety Relief Valve

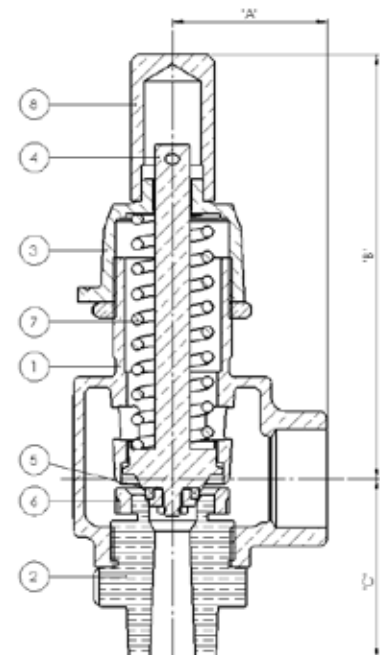





Safety Relief Valve  
Elbow



Safety Relief Valve  
Inlet Adaptor, Elbow,  
Downpipe & Coupling



Safety Relief Valve  
Inlet Adaptor



Safety Relief Valve  
Elbow, Downpipe &  
Coupling

## How to Order

The correct part number is easily derived from the following number sequence

### Nozzle 10

CW	F	20	J	H	05	N00
Series	Type	Valve Size	Inlet Connection	Outlet Connection	Pressure Range	Option
CW Cryogenic Safety Relief Valve	F Without Lever	20 11.40 mm	J ½" BSP-PL Male	H ¾" BSP-PL Female	05 25-39 psi (1.7-2.7 bar)	N00 No Drain N1 Elbow N2 Inlet Adaptor Elbow, Downpipe & Coupling N3 Inlet Adaptor N4 Elbow, Downpipe & Coupling
	L With Lever		K ½" BSP-TR Male	J ¾" BSP-TR Female	12 40-53 psi (2.8-3.6 bar)	
			L ½" NPT Male	K ¾" NPT Female	17 54-79 psi (3.7-5.4 bar)	
			M ¾" BSP-PL Male	L 1" BSP-PL Female	25 80-111 psi (5.5-7.6 bar)	
			N ¾" BSP-PL Male c/w 60° Cone	M 1" BSP-PL Male c/w 60° Cone	32 112-148 psi (7.7-10.2 bar)	
			P ¾" BSP-TR Male	N 1" BSP-TR Female	38 149-219 psi (10.3-15.1 bar)	
	R ¾" NPT Male	P 1" BSP-TR Male	48 220-289 psi (15.2-19.9 bar)	53 290-435 psi (20-30 bar)		
			R 1" NPT Female	63 420-580 psi (29-40 bar)		

### Nozzle 15

CW	F	30	M	T	06	N00
Series	Type	Valve Size	Inlet Connection	Outlet Connection	Pressure Range	Option
CW Cryogenic Safety Relief Valve	F Without Lever	30 14 mm	M ¾" BSP-PL Male	T 1¼" BSP-PL Female	06 25-47 psi (1.7-3.2 bar)	N00 No Drain
			P ¾" BSP-TR Male	U 1¼" BSP-TR Female	14 48-70 psi (3.3-4.8 bar)	
			R ¾" NPT Male	V 1¼" BSP-NPT Female	22 71-112 psi (4.9-7.7 bar)	
			S 1" BSP-PL Male		34 113-156 psi (7.8-10.7 bar)	
			T 1" BSP-TR Male		39 157-225 psi (10.8-15.5 bar)	
			U 1" NPT Male		49 226-320 psi (15.6-22 bar)	
					57 321-435 psi (22.1-30 bar)	
					75 436-580 psi (30.1-40 bar)	

### Nozzle 20

CW	F	40	T	T	04	N00
Series	Type	Valve Size	Inlet Connection	Outlet Connection	Pressure Range	Option
CW Cryogenic Safety Relief Valve	F Without Lever	40 20.50 mm	T 1" BSP-TR Male	T 1¼" BSP-PL Female	04 25-34 psi (1.7-2.3 bar)	N00 No Drain
			U 1" NPT Male	U 1¼" BSP-TR Female	10 35-54 psi (2.4-3.7 bar)	
			V 1¼" BSP-PL Male	V 1¼" NPT Female	19 55-74 psi (3.8-5.1 bar)	
			W 1¼" BSP-TR Male	W 1½" BSP-PL Female	24 75-109 psi (5.1-7.5 bar)	
			Y 1¼" NPT Male	Z 1½" NPT Female	31 110-159 psi (7.6-10.9 bar)	
					41 160-229 psi (11-15.8 bar)	
					50 230-309 psi (15.9-21.3 bar)	
					56 310-435 psi (21.4-30 bar)	

Please contact us for other options.

# Cryogenic Safety Relief Valve

Stainless Steel

Nozzle 10 - 20 (3/8" - 3/4")

A range of high quality Stainless Steel relief valves designed to comply with ISO 4126 (Safety Valves General Requirement), Ad-Merkblatt A2 (Safety Devices against Excess Pressure) and TUV requirements. They are eminently suited to the protection of static and road going cryogenic storage tanks against damaging over pressure.

There are three basic sizes, defined by the throat diameter and each is available with a variety of inlet and outlet connections.

The valve is designed and factory set to lift repeatedly within 2% of the set pressure and to reseat above 92% of set pressure. Spring pre-compression and blow down ring settings are sealed after test to inhibit unauthorized tampering.

Flow rates at 10% above set pressure.

All valves are degreased for oxygen duty, assembled in clean room conditions and sealed in robust polythene bags prior to dispatch.

Each valve is individually set and flow tested and then stamped with the date of manufacture and its own unique serial number prior to dispatch.

## Maximum Working Pressure (MWP)

Subject to end connections

Up to 40 bar (580 psi) at -196°C to + 65°C

## Technical

- Designed and engineered for use with Group 1 gases.
- Designed and manufactured to ISO 4126 (SVGR) ASTM B31.1, BS EN 1626
- Optional full material traceability backed by BS EN 10204 3.1/3.2 certification.

CE Marked according to the Pressure Equipment Directive

## Materials

	Stainless Steel
1. Body	Stainless Steel ASTM A351 CF8M
2. Seat	HT Brass BS EN 12164 CW721R
3. Adjusting Cap	SS ASTM A351 CF8M
4. Disc (Nozzle 10) Disc (Nozzle 15, 20)	Brass BS EN 12163 CW712R Phosphor Bronze BS EN 12163 CW451R
5. Seal	PTFE TF7196
6. Blow Down Ring	Gunmetal BS EN 1982 CC491K
7. Spring	Stainless Steel 302 S26 BS2056
8. Weather Proof Cap	SS 316 BS EN 10088-3 1.4401

\* Full Stainless Steel Relief Valve available on request.



Nozzle 10 Stainless Steel Safety Relief Valve



Nozzle 10 Stainless Steel



Nozzle 20 Stainless Steel

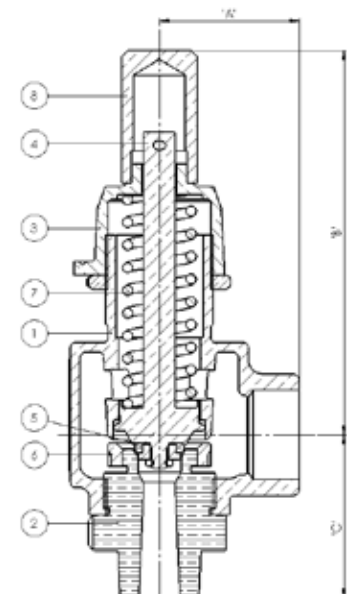

## Specifications

Size	Unit	Nozzle 10	Nozzle 15	Nozzle 20
A	mm	48	64	64
B	mm	130	133	133
C	mm	60	73	73
Weight	kg	1.5	3	3

## Technical Data

Inlet Orifice Dia (mm)	Set Pressure Range (Bar)	Inlet Sizes (BSP/NPT)	Outlet Sizes (BSP/NPT)
11.4	1.7 - 40	½" or ¾"	¾" or 1"
14	1.7 - 40	¾"	1¼"
20.50	1.7 - 30	1"	1¼"

## How to Order

Part Number	Valve Size (mm)	Inlet Connection	Outlet Connection	Pressure Range
<b>Nozzle 10</b>				
CWT20LK17N00	11.40mm	½" NPT Male	¾" NPT Female	54-79 psi (3.7-5.4 bar)
CWT20RK17N00		¾" NPT Male		
CWT20LR17N00		½" NPT Male	1" NPT Female	
CWT20RR17N00		¾" NPT Male		
CWT20LK25N00		½" NPT Male	¾" NPT Female	80-111 psi (5.5-7.6 bar)
CWT20RK25N00		¾" NPT Male		
CWT20LR25N00		½" NPT Male	1" NPT Female	
CWT20RR25N00		¾" NPT Male		
CWT20LK38N00		½" NPT Male	¾" NPT Female	149-219 psi (10.3-15.1 bar)
CWT20RK38N00		¾" NPT Male		
CWT20LR38N00		½" NPT Male	1" NPT Female	
CWT20RR38N00		¾" NPT Male		
CWT20LK48N00		½" NPT Male	¾" NPT Female	220-289 psi (15.2-19.9 bar)
CWT20RK48N00		¾" NPT Male		
CWT20LR48N00		½" NPT Male	1" NPT Female	
CWT20RR48N00		¾" NPT Male		
CWT20LK53N00		½" NPT Male	¾" NPT Female	290-435 psi (20-30 bar)
CWT20RK53N00		¾" NPT Male		
CWT20LR53N00		½" NPT Male	1" NPT Female	
CWT20RR53N00		¾" NPT Male		
<b>Nozzle 15</b>				
CWT30RV22N00	14mm	¾" NPT Male	1 ¼" NPT Female	71-112 psi (4.9-7.7 bar)
CWT30RV34N00				113-156 psi (7.8-10.7 bar)
CWT30RV39N00				157-225 psi (10.8-15.5 bar)
CWT30RV49N00				226-320 psi (15.6-22 bar)
<b>Nozzle 20</b>				
CWT40UV31N00	20.50	1" NPT Male	1 ¼" NPT Female	110-159 psi (7.6-10.9 bar)
CWT40UV74N00				290-362 psi (20-25 bar)

Please contact us for other options.

# Cryogenic Thermal Relief Valve

Brass

Nozzle 6 (1/4")

A compact cryogenic relief valve designed to prevent damage to piping and equipment caused by the expansion of liquefied gases.

When liquefied gases are trapped between two closed valves (a situation known as liquid lock) the reheating and consequent boiling can lead to a dangerous rise in pressure.

The Parker Bestobell Thermal Relief Valve has been designed with this application specifically in mind using materials which are particularly suited to this purpose. One major benefit of this is that the valve will not stick in its seat even when left unused for long periods of time. The valve also reseats correctly after venting off the expanding fluid, thus preventing the waste of expensive cryogenic gases. It is available with a variety of outlet connections to suit the customers' requirements.

All valves are degreased for oxygen duty, assembled in clean room conditions and pressure tested prior to dispatch.

## Maximum Working Pressure (MWP)

Subject to end connections

Up to 40 bar (580 psi) at -196°C to + 65°C

## Features

- Valve will not stick in its seat even when left unused for long periods of time
- Design allows the valve to reseat correctly after venting off the expanding fluid which prevents wastage of cryogenic gases
- Accuracy of lifting pressure is +/- 3%
- Valve is tight up until 90% of set pressure
- Valve reseats before 50% of set pressure
- Orifice diameter is 8mm



Pipe Away Adaptor



Nozzle 6 Brass Thermal Relief Valve  
Open to Atmosphere

## Technical

- Designed and engineered for use with Group 1 gases.
- Designed and manufactured in accordance with ASTM B31.1, BS EN 1626 and BS ISO 21011
- Optional full material traceability backed by BS EN 10204 3.1/3.2 certification.

CE Marked according to the Pressure Equipment Directive



Ring Pull

## Materials

	Brass
1. Body	Naval Brass BS EN 12163 CW712R
2. Disc	Hostaflon Electro Carbon Filled
3. Stem	Stainless Steel 10088-3 1.4401
4. Spring	Stainless Steel 302
5. Adjuster	Naval Brass BS EN 12163 CW712R

\* Stainless Steel version available on request.

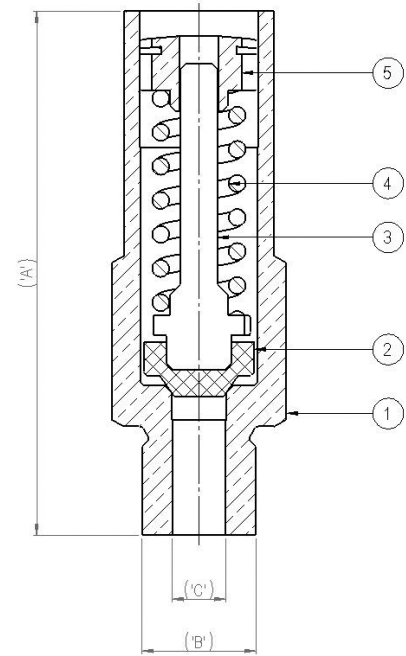

## Specifications

Pressure Ranges	
psi	bar
25 - 49	1.72 - 3.38
50 - 99	3.45 - 6.83
100 - 199	6.90 - 13.72
112 - 148	7.72 - 10.20
200 - 434	13.80 - 29.90
435 - 580	30.00 - 40.00

Outlet Type	Unit	A	C
Plain	mm	73	8
Ring Pull	mm	84	8
Male Threaded	mm	99	8
Shrouded	mm	93	8

B - Inlet Type (Male BSPT/NPT)

DN6 V2698 Thermal Relief Valve  
Flow in Kg/Hr @ 0 deg C Inlet & P+10%  
Area = 50mm squared

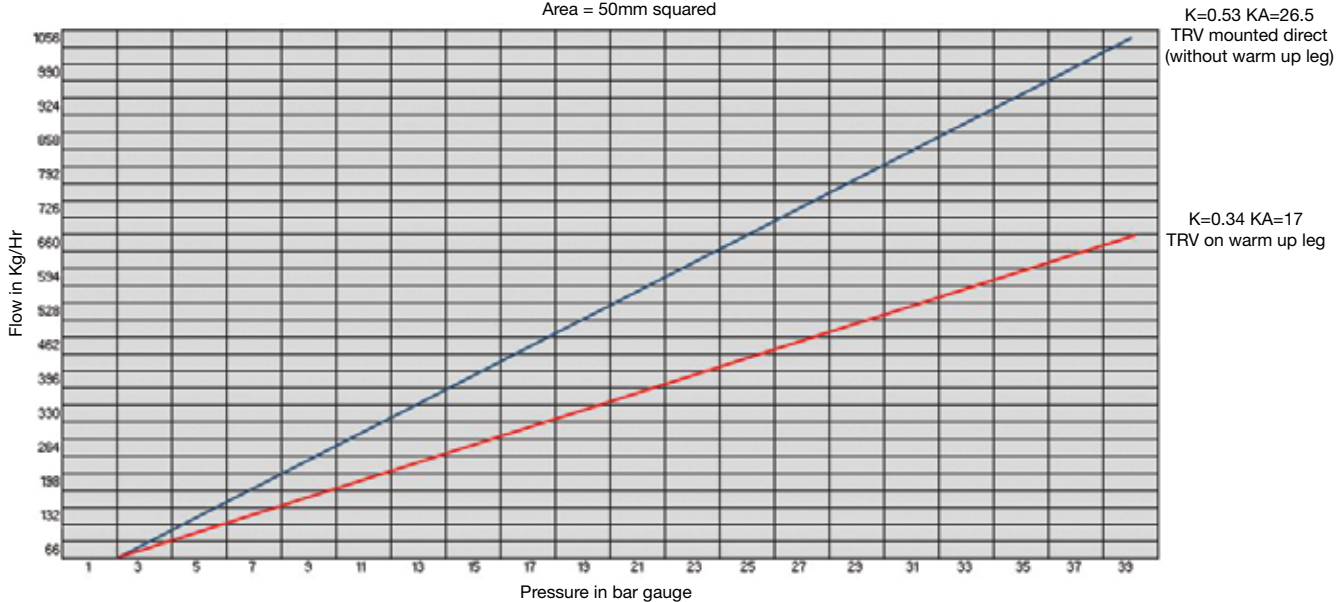

## How to Order

The correct part number is easily derived from the following number sequence

CVF	10	B	1	07	N00
Series	Valve Size	Inlet Connection	Outlet Connection	Pressure Range	Option
CVF Cryogenic Thermal Relief Valve	10 6.00mm	B 1/4" BSP-TR Male C 1/4" NPT Male K 1/2" BSP-TR Male L 1/2" NPT Male	1 Open to Atmosphere 3 Ring Pull C 1/2" BSP-TR F 1/2" NPT	07 25-49 psi (1.7-3.3 bar) 15 50-99 psi (3.4-6.8 bar) 29 100-199 psi (6.9-13.7 bar) 32 112-148 psi (7.7-10.2 bar) 45 200-434 psi (13.8-29.9 bar) 60 435-580 psi (30-40 bar)	N00 No Drain

Please contact us for other options.

# Cryogenic Pressure Regulator

## Pressure Build-Up Regulator and Economiser DN15 (1/2")

The Parker Bestobell "Cryoreg" is designed to provide all pressure regulation functions within one valve. Standard body material is bronze, yet also available in Stainless Steel. For use on all cryogenic pressure vessels including static tanks and transportable tanks, the Cryoreg valve combines all the following functions in one unit:

1. Pressure build up regulator
2. Economiser valve
3. Thermal relief\* on two of the ports

\*The "Cryoreg" provides thermal relief into the economiser outlet port for either of the other two ports (pressure build-up inlet and economiser inlet port). If a stop valve (as opposed to the Parker Bestobell check valve) is fitted to the economiser outlet port, a thermal relief valve should also be fitted.

All valves are degreased for oxygen duty, assembled in clean room conditions and pressure tested prior to dispatch.

### Maximum Working Pressure (MWP)

Subject to end connections

Up to 25 bar (360 psi) at -196°C to + 65°C

### Features

- Combined pressure build-up regulator and economiser functions for simpler pipework and fewer joints
- High flow characteristics – for closer control of tank pressure
- Operates on liquid or gas – to suit every installation
- Single adjustment for both functions – for simpler tank setting
- High accuracy/low deadband allows higher tank pressure – reduced boil-off in pipelines
- Dual thermal relief valve action – for added system protection
- Strainer fitted as standard on inlet and outlet
- Ball check fitted to economiser outlet as standard



DN15 Cryogenic Pressure Regulator Valve

### Technical

- Designed and engineered for use with Group 1 gases.
- DN15 – DN25 bull nose end connections available. Please contact us with your requirements.
- Designed and manufactured in accordance with ASTM B31.1, BS EN 1626 and BS ISO 21011
- Optional full material traceability backed by BS EN 10204 3.1/3.2 certification.

The Cryoreg is available with a choice of springs to give optimum control in all applications. Set pressure tolerance will normally be held on gas  $\pm 3\%$  and liquid side  $\pm 5\%$ .



DN15 with Bull Nose End Connections and Extended Stubs



DN15 with Bull Nose Connector and Socket Ends

## Materials

	<b>Bronze</b>
1. Body	Gunmetal BS EN1982 CC491K
2. Spring Housing	Gunmetal BS EN1982 CC491K
3. Seat	Bronze BS EN 12163 CW451K
4. Disc Assembly	Beryllium Copper/Phosphor Bronze
5. Spring	Stainless Steel Series 300
6. Seal	Virgin PTFE
7. Bellows Assembly	Stainless Steel Series 300
8. Strainer	Monel
9. Fasteners	Stainless Steel BS6105 A2/A4 Gr.70
10. Ball	Phosphor Bronze BS EN 12163 CW451K

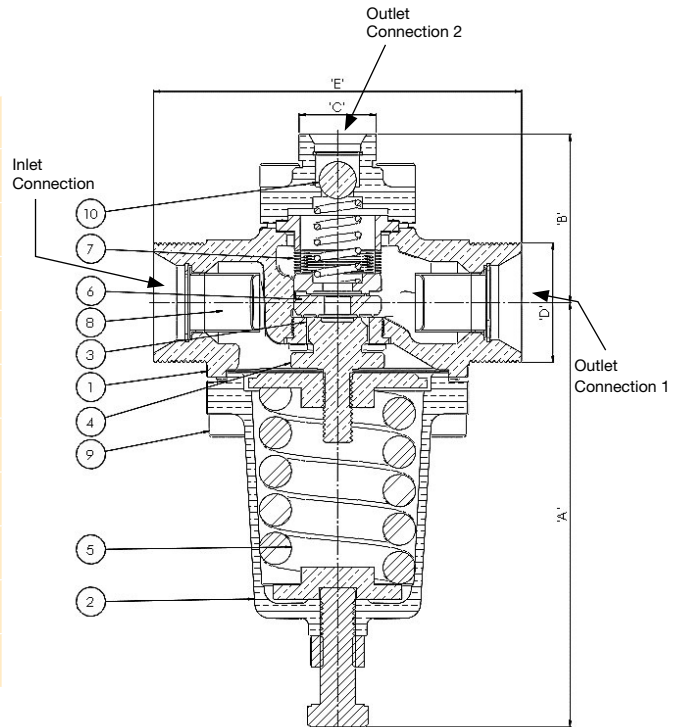

## Specifications

Pressure Ranges	Dimension					Weight (kg)
	A	B	C	D	E	
1.5 - 5 Bar	134	57.5	¾ BSP	1¼ BSP	126	3.5
4 - 12 Bar	134	57.5	¾ BSP	1¼ BSP	126	3.5
10 - 25 Bar	134	57.5	¾ BSP	1¼ BSP	126	3.5

## How to Order

The correct part number is easily derived from the following number sequence

CK	30	10	10	10	1	7000
Series	Valve Size Diameter Dominal (DN)	Inlet Connection	Outlet Connection 1	Outlet Connection 2	Thread Size	Pressure Range
CK Cryogenic Pressure Regulator	30 DN15	<b>10</b> 1¼" BSP-PL c/w 60° Cone	<b>10</b> 1¼" BSP-PL c/w 60° Cone	<b>10</b> ¾" BSP-PL c/w 60° Cone	<b>1</b> 1¼"	<b>7000</b> 22-73 psi (1.5-5 bar)
		<b>E3</b> ½" NPT Female	<b>E3</b> ½" NPT Female	<b>E2</b> ¾" NPT Female		<b>7100</b> 58-174 psi (4-12 bar)
		<b>E5</b> 1" NPT Female	<b>E5</b> 1" NPT Female	<b>E3</b> ½" NPT Female		<b>7200</b> 145-363 psi (10-25 bar)
		<b>S9</b> ½" NB x Butt Weld Schedule 10	<b>S9</b> ½" NB x Butt Weld Schedule 10	<b>E4</b> ¾" NPT Female		
		<b>SN</b> 1" NB x Butt Weld Schedule 10	<b>SN</b> 1" NB x Butt Weld Schedule 10	<b>S9</b> ½" NB x Butt Weld Schedule 10		

Please contact us for other options.

# Cryogenic Pressure Regulator

## Pressure Build-Up Regulator and Economiser DN15 (1/2")

### Description of Operation

In the following explanation of the “Cryoreg” it is assumed to be fitted downstream of the pressure build-up coil and will therefore be controlling a gaseous flow during the pressure build-up phase of its operation. Operation is identical when fitted upstream of the PBU coil except that liquid will be passed during the pressure build-up phase.

### First Function

Pressure build-up regulator

As the customer draws liquid or gas from the tank the pressure inside the tank will fall. To compensate for this, the “Cryoreg” will open to allow liquid to pass through the pressure build-up coil. Sufficient gas will thus be generated to bring the tank back to its normal working pressure.

In this phase of operation, flow is from port A to port B via the pressure build-up seat on the multi-function disc, the flow path being formed from the upward movement of the diaphragm assembly lifting the multi-function disc away from the main seat. This upward movement arises as a result of the force in the pressure setting spring overcoming the pressure force acting over the sensing diaphragm. As soon as the pressure in the tank has recovered, the diaphragm assembly is pushed back down again, closing off the flow path.

### Second Function

Economiser Valve

When heat leaks into a cryogenic storage tank, liquid will revert to its gas phase leading to a pressure rise in the tank. Left unchecked, the process may continue until the relief valve lifts, wastefully venting gas to atmosphere. The function of an economiser valve is to divert excess gas into the customer’s supply line. Providing the customer is drawing gas, diverting the flow in this manner will prevent the relief valve lifting, avoiding waste and reducing the overall cost of storing the liquefied gas. To accomplish this; a flow path is formed within the “Cryoreg” to allow gas to pass from port B, up through the centre of the valve to exit via the economiser port C. The flow path is formed from the downward movement of the diaphragm (which senses tank pressure) having overcome over the force in the pressure setting spring. This occurs when the tank pressure exceeds the valve set pressure by more than 0.54 barg.

Note that this mechanism is also used to provide thermal relief into the economiser from outlet B.

### Third function

Thermal relief

Inadvertent closure of the valve supplying the pressure build-up coil could lead to liquid being trapped between the coil and the “Cryoreg”. A thermal relief valve would normally be required to protect the coil-associated pipework from the high pressures generated by warming of the trapped liquid. This function, however, is built in to the “Cryoreg”, which will automatically vent the gas into either the economiser line (port C) or the gas supply line to the tank (port A). This function is accomplished by the differential pressure across the bellows forcing it to compress, leaving the multi-function disc in place. This allows a flow path to form from port A, up through the centre of the bellows to exit from the economiser port. Remember that thermal relief is provided on port B by the economiser function described above giving protection under all foreseeable circumstances.

Note that if an isolating valve is fitted in the economiser line it will be necessary to fit a separate Thermal Relief Valve between the economiser port (C) and the isolation valve. This is not necessary if a Parker Bestobell Check Valve is installed.

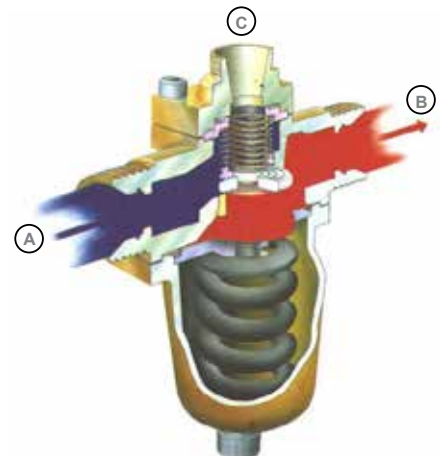

First function

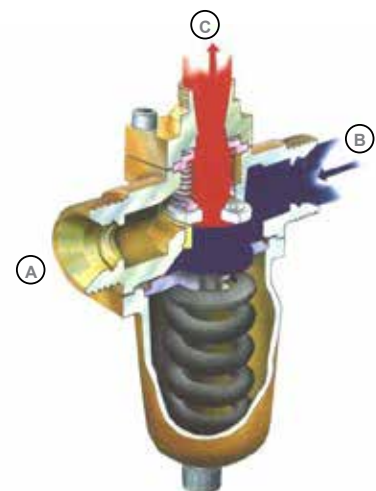

Second function

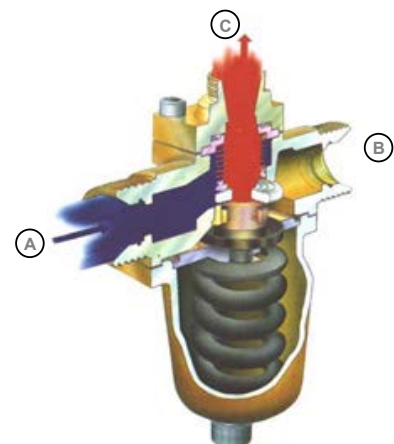

Third function



$Q = kw \sqrt{\Delta p} / \rho$  where  
 $Q$  = Actual flow in m<sup>3</sup>/h  
 $\Delta p$  = Pressure drop in bar  
 $\rho$  = Liquid density in kg/m<sup>3</sup>

### Cryoreg Flow Data

Cryoreg on liquid side of vapouriser

Flow rates given are in kg/hr with 1 meter liquid head in vessel. For change in liquid head multiply flow by square root liquid head.

#### Maximum Flow through regulator to give pressure build kg/hr

Bar g		2	4	6	8	10	12	14	16	18	20	25	30	35	40
psi g		29	58	87	116	145	174	203	232	261	290	362.5	435	507.5	580
LIN	kg/hr	513	499	477	460	445	431	418	407	393	378	347	310	-	-
LOX	kg/hr	728	711	686	667	651	636	622	609	595	581	551	524	495	467
LAR	kg/hr	888	888	837	813	792	774	757	741	726	704	669	634	597	563
CO2	kg/hr	-	-	758	746	727	715	703	692	681	672	648	627	607	586

#### Maximum gas withdrawal from tank M3/hr

Bar g	psi g	LIN M3/hr	LOX M3/hr	LAR M3/hr	CO2 M3/hr	Liquid Density kg/M3				Vapour Density kg/M3			
						LIN	LOX	LAR	CO2	LIN	LOX	LAR	CO2
2	29	25313	48940	43151	-	LIN	LOX	LAR	CO2	LIN	LOX	LAR	CO2
4	58	14544	28991	25388	-	780	1106	1350	-	12.45	11.4	15.4	-
6	87	9434	18940	16929	24155	758	1080	1319	-	20.24	18.2	24.8	-
8	116	6708	13798	12359	17835	725	1043	1272	1152	28.19	25.8	34.3	18
10	145	5014	10680	9494	13646	699	1014	1235	1134	36.35	33.2	43.9	23.5
12	174	3861	8533	7549	11184	676	989	1204	1105	44.8	40.4	53.8	29
14	203	3040	6998	6141	9379	655	966	1176	1086	53.7	47.9	63.9	34
16	232	2436	5805	5080	8006	636	946	1150	1068	63.1	55.4	74.3	39
18	261	1938	4867	4267	6786	618	925	1126	1051	72.8	63.2	85.1	44
20	290	1537	3991	3552	5968	597	904	1103	1035	83.3	71.2	96	50
25	362.5	877	2664	2409	4285	574	883	1070	1021	94.3	81.6	107	55
30	435	507	1841	1669	3281	527	838	1017	985	126.6	106.0	137	70
35	507.5	-	1262	1131	2522	471	796	963	953	154.6	132.2	169	84
40	580	-	853	750	1901	-	752	907	922	-	162.0	207	100
						-	710	855	890	-	196.8	253	120

# Cryogenic Pressure Build Up Valve

Stainless Steel  
DN50 (2")

The Parker Bestobell Pressure Build Up Valve is designed to provide an 'easy adjust' pressure regulation function in one valve.

It is suitable for use on cryogenic static tanks and road trailers. The valve operation is such that it maintains a system pressure on a container or storage unit during transfer of gas from the trailer to a storage unit or vice versa. Pressure must be maintained to allow flow to occur at desired rates during transfer.

All valves are degreased for oxygen duty, assembled in clean room conditions and pressure tested prior to dispatch.

## Maximum Working Pressure (MWP)

Subject to end connections

Up to 50 bar (725 psi) at -196°C to +65°C

## Features

- High flow characteristics for closer control of tank pressure
- Operates on liquid or gas to suit every installation
- Single adjustment for ease of tank setting
- Inlet strainer fitted as standard fitted as standard to all valves
- Removable cartridge internal system for ease of maintenance
- Available with a choice of springs to give optimum control in all applications

## Technical

- Designed for use with: C, Ar, O<sub>2</sub>, CO<sub>2</sub>
- DN50 Flow data: Cv = 12.5 US GPM; Kv = 10.8 M<sup>3</sup>/hr
- Optional full material traceability backed by BS EN 10204 3.1/3.2 certification.



DN50 Cryogenic Stainless Steel  
Pressure Build Up Valve

## Materials

	Bronze
1. Body	Stainless Steel ASTM A351 CF3M
2. Spring Housing	HT Brass BS EN 12164 CW721R
3. Pressure Plates	HT Brass BS EN 12164 CW721R
4. Cover	Stainless Steel ASTM A351 CF8M
5. Bellows	Stainless Steel
6. Stem	Brass HT Brass BS EN 12164 CW721R
7. Piston Housing	Phosphor Bronze BS EN 12163 CW451K
8. Strainer	Stainless Steel 316
9. Spring	Stainless Steel 302
10. Seal	Virgin PTFE
11. Piston	HT Brass BS EN 12164 CW721R

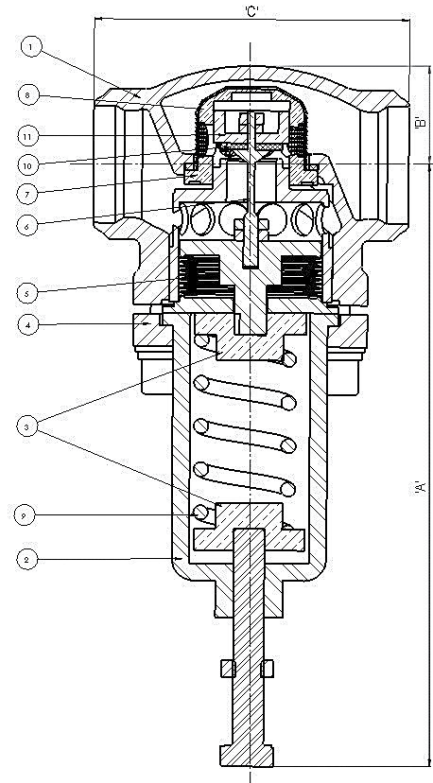

## Specifications

### Butt Weld Ends

Size	Unit	DN50 2"
A	mm	243
B	mm	48
C	mm	146
Weight	kg	9

Size	Spring Adjustment Range (psi)
DN50 (1.5-9 bar)	22-130

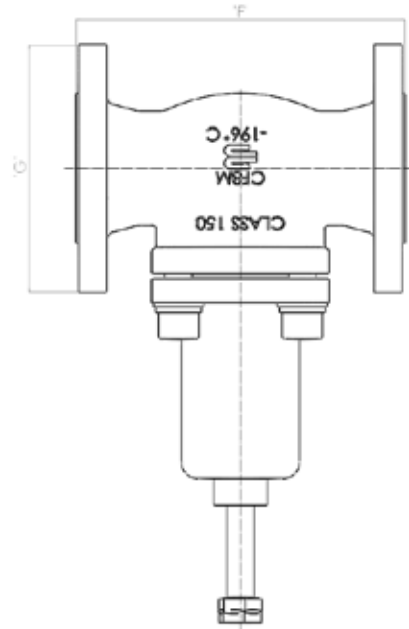

### Flanged Ends (Class 150)

Size	Unit	DN50 2"
F	mm	203
G	mm	152
Flange Thickness	mm	19
Weight	kg	14

Class 300 valves available on request

## How to Order

Part Number	Valve Size Diameter Nominal (DN)	Connection Type	Pressure Range (psi)
CF80B1B17000	50	Butt Weld Schedule 10	22 - 130
CF80FAFA7000		Flange Class 150	
CF80FCFC7000		Flange Class 300	

Please contact us for other options.

# Cryogenic Lift Check Valve

Stainless Steel

DN6 - DN150 (1/4" - 6")

Parker Bestobell lift check valves feature bolted bonnet, integral seat and renewable PTFE seal, complete with bronze internals. The Stainless Steel body valves are available with flanged, Butt Weld and Socket Ends. The lift check valve is of a cone seat design for zero leak shut off.

The bolted bonnet allows for easy maintenance, even in confined spaces.

All valves are degreased for oxygen duty, assembled in clean room conditions and pressure tested prior to dispatch.



DN80 Stainless Steel Lift Check Valve with Socket Ends

## Maximum Working Pressure (MWP)

Subject to end connections

Up to 50 bar (725 psi) at -196°C to +65°C

## Features

- Unique Parker Bestobell loose flange bolted bonnet design allows for thermal expansion and contraction and eliminates leakage at the bonnet gasket
- Precision investment cast body – smooth surface finish
- PTFE seal to ensure tight shut off at all times
- Designed and engineered specifically for cryogenic service
- Full bore
- Fast/easy maintenance of PTFE components

## Technical

- Designed and engineered for use with Group 1 gases.
  - Designed and manufactured in accordance with ASTM B31.1, BS EN 1626 and BS ISO 21011.
  - Optional full material traceability backed by BS EN 10204 3.1/3.2 certification.
- CE Marked according to the Pressure Equipment Directive.



DN40 Butt Weld



DN40 Flanged Ends



DN40 Socket Ends

## Materials

	<b>Stainless Steel</b>
1. Body	Stainless Steel ASTM A351 CF8M
2. Cover	Stainless Steel BS EN 10088-3 1.4401
3. Disc	HT Brass BS EN 12164 CW721R
4. Seal	Virgin PTFE
5. Gasket Bonnet	Sigma 511
6. Bonnet Flange	Stainless Steel - ASTM A351 CF8M
7. Fasteners	Stainless Steel BS6105 A2/A4 Gr.70

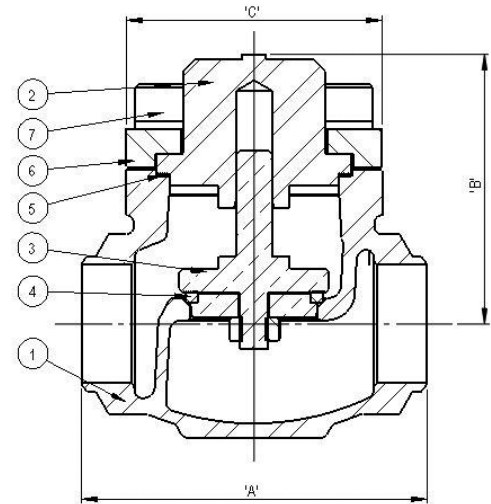

## Specifications

### Butt Weld Ends

Size	Unit	DN6 1/4"	DN10 3/8"	DN15 1/2"	DN20 3/4"	DN25 1"	DN40 1 1/2"	DN50 2"	DN65 2 1/2"	DN80 3"	DN100 4"	DN150 6"
A	mm	68	68	68	92	92	121	146	178	178	292	400
B	mm	51	51	51	60	71	84	107	145	145	193	260
C	mm	55	55	55	66	66	81	108	130	133	169	305
Cv	US GPM	3.6	3.6	3.6	13.2	13.2	26.5	43	68	98	174	400
Weight	kg	1	1	1	1.5	1.6	3.2	6.5	9	13.4	35	110
Opening Pressure	PSI	0.37	0.37	0.37	0.37	0.37	0.24	0.21	0.25	0.27	0.34	0.5

### Flanged Ends (Class 300)

Size	Unit	DN15 1/2"	DN20 3/4"	DN25 1"	DN40 1 1/2"	DN50 2"	DN65 2 1/2"	DN80 3"	DN100 4"	DN150 6"
F	mm	130	160	160	200	230	290	310	350	406
G	mm	95	124	124	155	165	191	210	254	279
Flange Thickness	mm	14	18	18	21	22	25	28	32	25
Weight	kg	2.2	4.5	4.5	8.6	13.5	19.5	27.4	53	125

Class 150 valves available on request  
DN150 sizes are to Class 150 pressures only

## How to Order

The correct part number is easily derived from the following number sequence

CGT	10	B1	B	0	C
Series	Valve Size Diameter Nominal (DN)	Connection Type	Bonnet	Option	Seat Type
CGT	10 DN6	B1 Butt Weld Schedule 10	B Bolted	0 Without Spring	C Cone
Cryogenic	20 DN10	SNE Socket Weld			
Lift Check	30 DN15	FA Flange Class 150			
Stainless Steel	40 DN20	FC Flange Class 300			
	50 DN25				
	70 DN40				
	80 DN50				
	90 DN65				
	A0 DN80				
	B0 DN100				
	D0 DN150				

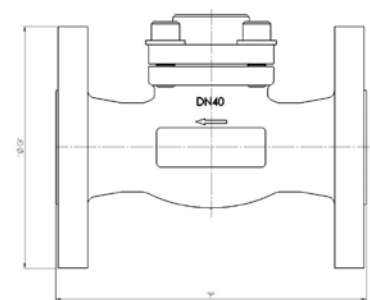

Please contact us for other options.

# Cryogenic Lift Check Valve

Bronze

DN6 - DN50 (1/4" - 2")

Parker Bestobell lift check valves feature bolted bonnet, integral seat and renewable PTFE disc, complete with bronze internals. The bronze body valves are available with Socket Ends or BSP Parallel/NPT threaded end connections and Stainless Steel stubs. The lift check is of a cone seat design for zero leak shut off.

The bolted bonnet allows for easy maintenance, even in confined spaces with lower bolting torques.

All valves are degreased for oxygen duty, assembled in clean room conditions and pressure tested prior to dispatch.

## Maximum Working Pressure (MWP)

Subject to end connections

Up to 50 bar (725 psi) at -196°C to +65°C

## Features

- Unique Parker Bestobell loose flange bolted bonnet design allows for thermal expansion and contraction and eliminates leakage at the bonnet gasket
- PTFE seal to ensure tight shut off at all times
- Designed and engineered specifically for cryogenic service
- Full bore
- Fast/easy maintenance of PTFE components



DN15 Bronze Lift Check Valve with Socket Ends

## Technical

- Designed and engineered for use with Group 1 gases.
  - Designed and manufactured in accordance with ASTM B31.1, BS EN 1626 and BS ISO 21011.
  - Optional full material traceability backed by BS EN 10204 3.1/3.2 certification.
- CE Marked according to the Pressure Equipment Directive.



DN25 with Stainless Steel Stubs

## Materials

	<b>Bronze</b>
1. Body	Gunmetal BS EN 1982 CC491K
2. Cover	Stainless Steel BS EN 10088-3 1.4401
3. Disc	HT Brass BS EN 12164 CW721R
4. Seal	Virgin PTFE
5. Gasket Bonnet	Sigma 511
6. Bonnet Flange	Stainless Steel - ASTM A351 CF8M
7. Fasteners	Stainless Steel BS6105 A2/A4 Gr.70

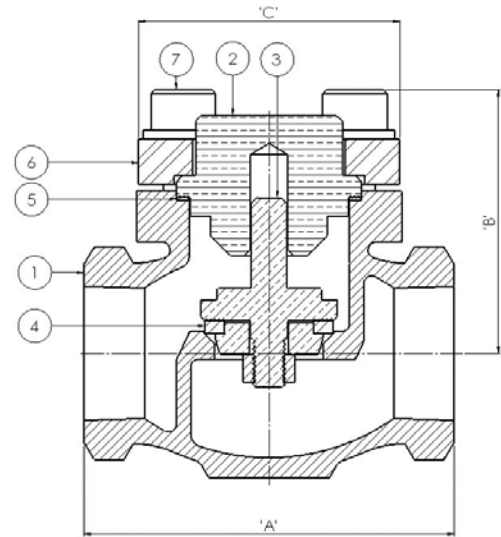

## Specifications

Size	Unit	DN6 1/4"	DN10 3/8"	DN15 1/2"	DN20 3/4"	DN25 1"	DN40 1 1/2"	DN50 2"
A	mm	68	68	68	76	92	121	146
B	mm	51	51	51	60	71	84	107
C	mm	55	55	55	66	66	81	108
Cv	US GPM	3.6	3.6	3.6	6.2	13.2	26.5	43
Weight	Kg	1	1	1	1.3	1.8	3.7	6.4
Opening Pressure	PSI	0.37	0.37	0.37	0.37	0.37	0.24	0.21

Non Return  
Check Valves

## How to Order

The correct part number is easily derived from the following number sequence

<b>CGB</b>	<b>10</b>	<b>TA</b>	<b>B</b>	<b>0</b>	<b>C</b>
Series	Valve Size Diameter Nominal (DN)	Connection Type	Bonnet	Option	Seat Type
<b>CGB</b> Cryogenic Bronze Lift Check	<b>10</b> DN6 <b>20</b> DN10 <b>30</b> DN15 <b>40</b> DN20 <b>50</b> DN25 <b>70</b> DN40 <b>80</b> DN50	<b>TA</b> BSP-PL <b>TE</b> NPT <b>SST</b> Stainless Steel Stubs	<b>B</b> Bolted	<b>0</b> Without Spring	<b>C</b> Cone

Please contact us for other options.

# Cryogenic Swing Check Valve

Stainless Steel

DN25 - DN80 (1" - 3")

A Stainless Steel swing check valve with a PTFE seal incorporated into the valve disc ensures a drop tight shut off at ambient temperatures and a leakage rate complying with EN1626 "Valves for Cryogenic Service" under cryogenic conditions.

A wide opening allows high flow rates at low-pressure drops.

The design incorporates a bolted bonnet and a unique easy assemble valve disc assembly.

All valves are degreased for oxygen duty, assembled in clean room conditions and pressure tested prior to dispatch.

## Maximum Working Pressure (MWP)

Subject to end connections

Up to 50 bar (725 psi) at -196°C to +65°C

## Features

- Designed and engineered specifically for cryogenic service
- Precision investment cast body – smooth surface finish
- Lapped seating face to ensure tight shut-off
- Offset centre of gravity of the disc assembly
- The disc hits the seat face squarely giving even wear across the seal
- Improved low differential pressure seating
- Very low leak rates achievable
- Unique Parker Bestobell cover to avoid incorrect assembly
- PTFE seal to ensure tight shut off



DN50 Stainless Steel Swing Check Valve with Butt Weld Ends

## Technical

- Designed and engineered for use with Group 1 gases.
  - Designed and manufactured in accordance with ASTM B31.1, BS EN 1626 and BS ISO 21011.
  - Optional full material traceability backed by BS EN 10204 3.1/3.2 certification.
- CE Marked according to the Pressure Equipment Directive.



DN25 Butt Weld Ends



DN50 Flanged Ends



## Materials

	<b>Stainless Steel</b>
1. Body	Stainless Steel ASTM A351 CF8M
2. Cover	Stainless Steel ASTM A351 CF8M
3. Disc	Stainless Steel BS EN 10088-3 1.4401
4. Seal	Virgin PTFE
5. Arm	Stainless Steel ASTM A351 CF8M
6. Fasteners	Stainless Steel BS6105 A2/A4 Gr.70
7. Gasket	Sigma 511

## Specifications

### Butt Weld Ends

Size	Unit	DN25	DN40	DN50	DN80
A	mm	92	121	146	260
B	mm	64	73	92	110
C	mm	70	110	125	155
Cv	US GPM	20	48	90	192
Weight	kg	2	3.8	5.9	15.2
Opening Pressure	PSI	0.21	0.22	0.22	0.5

### Flanged Ends (Class 300)

Size	Unit	DN25 1"	DN50 2"	DN80 3"
F	mm	127	203	241
G	mm	108	152.4	190.5
Flange Thickness	mm	11	19	23.8
Weight	Kg	3.3	10	20

## How to Order

Part Number	Valve Size Diameter Nominal (DN)	Option	End connection
CHC50UB100	DN25	Without Spring	Butt Weld Schedule 10
CHC70UB100	DN40	Without Spring	Butt Weld Schedule 10
CHC80UB100	DN50	Without Spring	Butt Weld Schedule 10
CHCA0UB100	DN80	Without Spring	Butt Weld Schedule 10

Please contact us for other options.

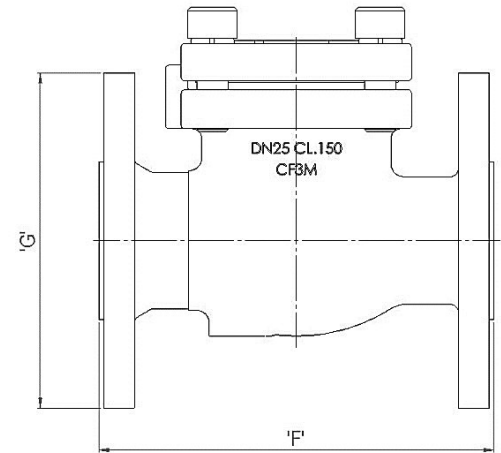
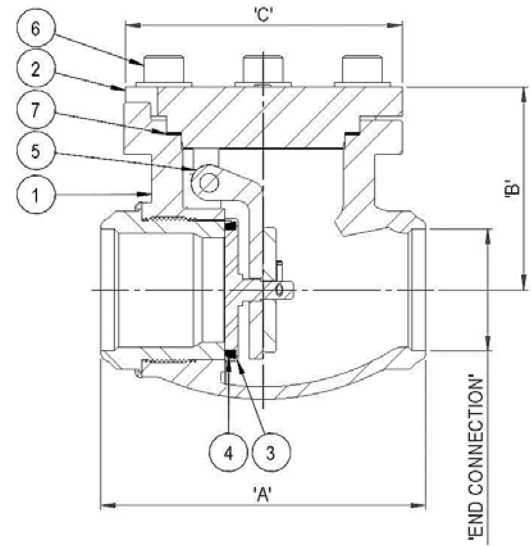

Non Return  
Check Valves

# Cryogenic Strainer

Stainless Steel

DN6 - DN100 (1/4" - 4")

Cryogenic strainers with Stainless Steel bodies are available with Socket Weld, Butt Weld & Flanged Ends. Bolted bonnet allows for easy maintenance.

100 mesh filters are supplied as standard, other mesh sizes are available on request.

All valves are degreased for oxygen duty, assembled in clean room conditions and pressure tested prior to dispatch.

## Maximum Working Pressure (MWP)

Subject to end connections

Up to 50 bar (725 psi) at -196°C to +65°C

## Features

- Unique Parker Bestobell loose flange bolted bonnet design allows for thermal expansion and contraction and eliminates leakage at the bonnet gasket
- Precision investment cast body – smooth surface finish
- Designed and engineered specifically for cryogenic service
- Full bore
- Adequate strainer area to ensure full flow of fluid through the unit



DN40 Stainless Steel Strainer with Butt Weld Ends

## Technical

- Designed and engineered for use with Group 1 gases.
  - Designed and manufactured in accordance with ASTM B31.1, BS EN 1626 and BS ISO 21011.
  - Optional full material traceability backed by BS EN 10204 3.1/3.2 certification.
- CE Marked according to the Pressure Equipment Directive.



DN40 Flanged Ends



DN100 Butt Weld Ends

## Materials

Stainless Steel	
1. Body	Stainless Steel ASTM A351 CF8M
2. Cover	Stainless Steel BS EN 10088-3 1.4401
3. Gasket	Sigma 511
4. Loose Flange	Stainless Steel ASTM A351 CF8M
5. Fasteners	Stainless Steel BS6105 A2 / A4 Gr.70
6. Filter	Copper / Monel Gauze

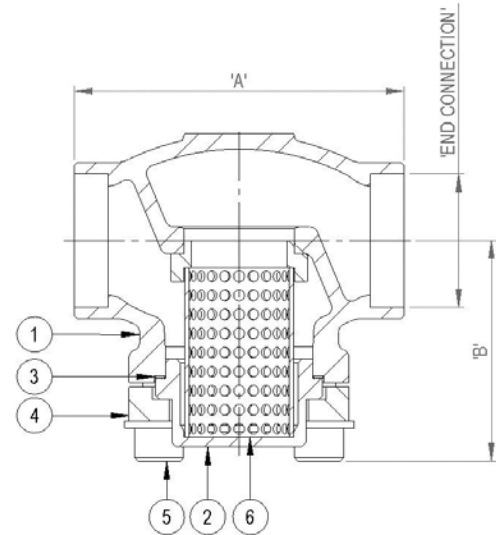

## Specifications

### Butt Weld Ends

Size	Unit	DN6 1/4"	DN10 3/8"	DN15 1/2"	DN20 3/4"	DN25 1"	DN40 1 1/2"	DN50 2"	DN65 2 1/2"	DN80 3"	DN100 4"
A	mm	68	68	68	92	92	121	146	178	178	292
B	mm	55	55	55	66	66	81	108	145	160	229
Cv	US GPM	16	16	16	44	44	80	128	192	260	390
Weight	kg	1	1	1	1.6	2	2.6	5.4	7	10	33

### Flanged Ends (Class 300)

Size	Unit	DN6 1/4"	DN10 3/8"	DN15 1/2"	DN20 3/4"	DN25 1"	DN40 1 1/2"	DN50 2"	DN65 2 1/2"	DN80 3"	DN100 4"
F	mm	130	130	130	160	160	200	230	290	310	350
G	mm	95	95	95	124	124	155	165	191	210	254
Flange Thickness	mm	14	14	14	18	18	21	22	25	28	32
Weight	kg	2.2	2.2	2.2	5	5	8	12.4	17.5	24	51

## How to Order

The correct part number is easily derived from the following number sequence

CS	10	B1	F	BY
Series	Valve Size Diameter Nominal (DN)	Connection Type	Filter Material	Filter Size
CS Cryogenic Strainer	10 DN6	<b>B1</b> Butt Weld Schedule 10	<b>F</b> Copper/Monel	<b>BY</b> 100 mesh
	20 DN10	<b>SNE</b> Socket Weld		
	30 DN15	<b>FA</b> Flange Class 150		
	40 DN20	<b>FC</b> Flange Class 300		
	50 DN25			
	70 DN40			
	80 DN50			
90 DN65				
A0 DN80				
B0 DN100				

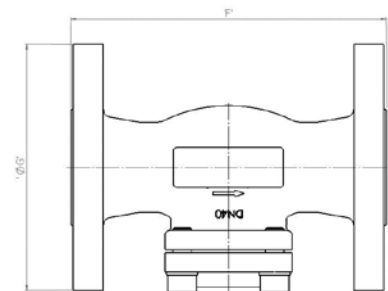

Please contact us for other options.

# Cryogenic Strainer

Bronze

DN6 - DN50 (1/4" - 2")

Cryogenic strainers with bronze bodies are available with Socket Weld, Stainless Steel Stubs and threaded ends. Bolted bonnet allows for easy maintenance.

100 mesh filters are supplied as standard however other mesh sizes can be supplied on request.

All valves are degreased for oxygen duty, assembled in clean room conditions and pressure tested prior to dispatch.

## Maximum Working Pressure (MWP)

Subject to end connections

Up to 50 bar (725 psi) at -196°C to +65°C

## Features

- Unique Parker Bestobell loose flange bolted bonnet design allows for thermal expansion and contraction and eliminates leakage at the bonnet gasket
- Designed and engineered specifically for cryogenic service
- Full bore
- Adequate strainer area to ensure full flow of fluid through the unit

## Technical

- Designed and engineered for use with Group 1 gases.
  - Designed and manufactured in accordance with ASTM B31.1, BS EN 1626 and BS ISO 21011.
  - Optional full material traceability backed by BS EN 10204 3.1/3.2 certification.
- CE Marked according to the Pressure Equipment Directive.



DN25 Bronze Strainer with Socket Weld Ends



DN25 with Stainless Steel Stubs

## Materials

	Stainless Steel
1. Body	Gunmetal BS EN 1982 CC491K
2. Cover	Stainless Steel BS EN 10088-3 1.4401
3. Gasket	Sigma 511
4. Loose Flange	Stainless Steel ASTM A351 CF8M
5. Fasteners	Stainless Steel BS6105 A2 / A4 Gr.70
6. Filter	Copper / Monel Gauze

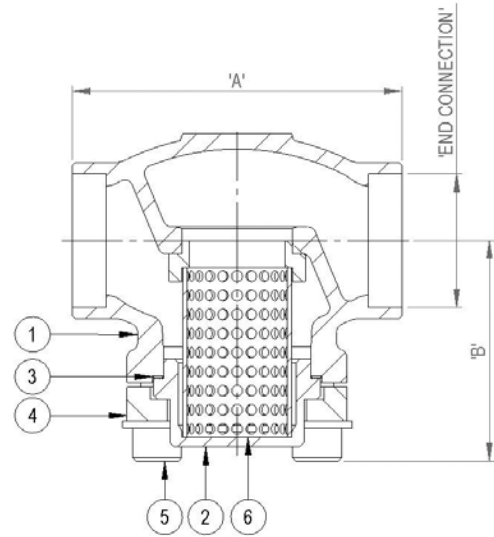

## Specifications

Size	Unit	DN6 1/4"	DN10 3/8"	DN15 1/2"	DN20 3/4"	DN25 1"	DN40 1 1/2"	DN50 2"
A	mm	68	68	68	76	92	121	146
B	mm	55	55	55	66	66	81	108
Cv	US GPM	16	16	16	44	44	80	128
Weight	kg	1	1	1	1.6	1.8	3.1	5.1

## How to Order

The correct part number is easily derived from the following number sequence

CS	10	TA	F	BY
Series	Valve Size Diameter Nominal (DN)	Connection Type	Filter Material	Filter Size
CS Cryogenic Strainer	10	DN6	F Copper/Monel	BY 100 mesh
	20	DN10		
	30	DN15		
	40	DN20		
	50	DN25		
	70	DN40		
	80	DN50		
		TA BSP-PL TE NPT SST Stainless Steel Stubs		

Please contact us for other options.

# Automatic Sensing Pressure Reversing Obturator

Stainless Steel

DN6 & DN20 (1/4" & 3/4")

The Automatic Sensing Pressure Reversing Obturator (ASPRO) is a concept that addresses the issue of back contamination from high-pressure carbon dioxide cylinders removing the opportunity for gas contamination. This is a particular problem in the food and beverage industry, where on numerous occasions, contamination has occurred leading to product recalls and brand damage.

There are also a growing number of applications in pharmaceutical production and clean process used in industrial production.

The ASPRO was developed for the prevention of back contamination of CO<sub>2</sub> from a high-pressure cylinder, or dewer to the main flow stream, preventing back flow pressures up to 3600psi (250bar), in accordance with recommendations requested by EIGA and BCGA.

The flow co-efficient (CV) allows full flow of media from filling stations and portable delivery systems therefore no delay in filling time.

## Maximum Working Pressure (MWP)

Subject to end connections

DN6 - 110bar (1600 psi)

DN20 - 207bar (3000 psi)

Temperature range -20°C to +65°C

## Features

- Fully automatic: no operator involvement required to operate the valve

(Please note - The above temperature rating is primarily for CO<sub>2</sub>. Other operating temperatures, for different media, are available upon request)

- Designed for single point filling lines



DN20 Stainless Steel ASPRO Valve

## Technical

- Designed and engineered for use with Group 1 gases.
- Designed and manufactured in accordance with ASTM B31.1, BS EN 1626 and BS ISO 21011.

## Materials

	Stainless Steel
1. Shuttle Valve	Stainless Steel 316 BS EN 10088-3 1.4401
2. Diaphragm Valve	Stainless Steel 316 BS EN 10088-3 1.4401
3. Pipe to Upstream	Stainless Steel ASTM A351 TP316L
4. Pipe to Vent	Stainless Steel ASTM A351 TP316L
5. Pipe to Downstream	Stainless Steel ASTM A351 TP316L

## Specifications

Size	Unit	DN6 1/4"	DN20 3/4"
A	mm	110	238
B	mm	64	51
C	mm	230	57
D	mm	-	140
E	mm	-	192
F	mm	-	57
G	mm	-	278
Weight	kg	4	4

DN6: 1/4" TR ONLY

DN20: 3/4" TR, 1/2" Socket Weld

## How to Order

Part Number	Valve Size Diameter Nominal (DN)	Connection Type
CXC10TC00	DN6	BSP-TR
CXC40TC00	DN20	BSP-TR
CXC40SNB0C		Socket Weld

Please contact us for other options.

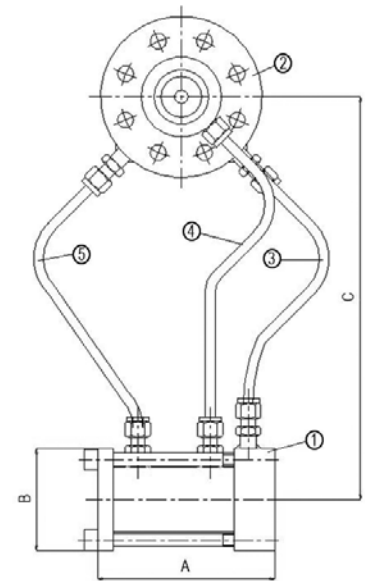
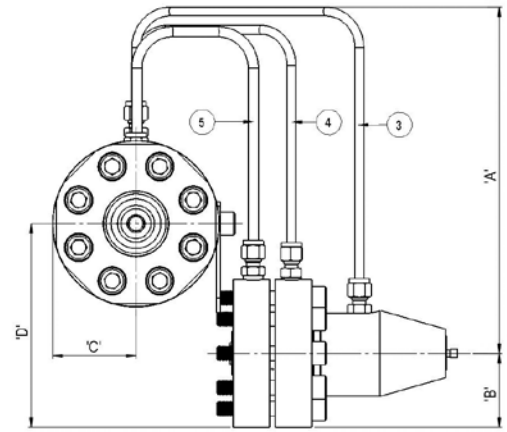

DN6

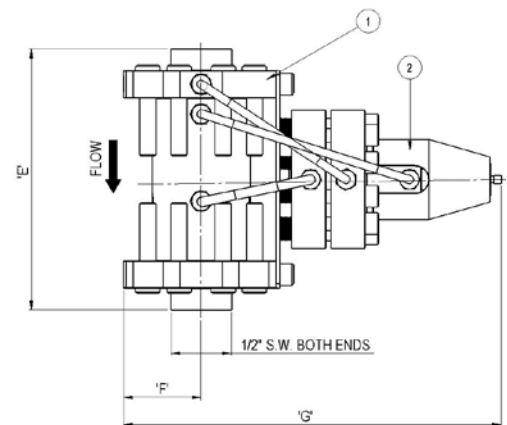

DN20

# Flow Diverter Ball Valve

Bronze

DN20 - DN50 (3/4" - 2")

The Parker Bestobell flow diverter is a quarter turn ball valve design allowing for fast changeover between relief valves.

It is essential that a cryogenic liquid storage vessel is always protected by a relief valve. If only one relief valve was fitted to the vessel it would be impossible to disconnect for routine maintenance or checking of lifting pressures without prejudicing the safety of the vessel.

For this reason, all cryogenic storage tanks require two relief valves to be connected to the tank via a flow diverter valve. This allows one relief valve to remain connected to the vessel while the other undergoes maintenance.

The Parker Bestobell flow diverter ball valve is available in a wide range of configurations. The valve comprises three main components: the centre body incorporating the inlet port, ball and operating lever, and the two end adaptors incorporating the various outlet ports. It is available in four basic sizes (DN20, DN25, DN32 and DN50) determined by the diameter of the flow passages through the ball.

This valve is usually at the hub of a fairly complex piping system and many variations on the basic design have evolved to suit customers' specific requirements. An outline of the various options is given for simplicity; the centre body is described separately from the end flanges.

All valves are degreased for oxygen duty, assembled in clean room conditions and pressure tested prior to dispatch.

## Maximum Working Pressure (MWP)

Subject to end connections

Up to 50 bar (725 psi) at -196°C to +65°C

## Features

The position of the entry port helps the system designer to fit the valve into the particular space and available position. With the bottom entry valve, the inlet port is on the opposite side of the centre body from the opening lever (see drawing). The front entry valve has the inlet port on the face at 90° to the operating lever (photograph). The DN20, DN32 and DN50 valves are available with bottom or front entry configurations.

The three position "T"-port offers significant advantages. The first of these is that it is possible to have both relief valves connected to the storage vessel (or mobile tanker) at one time. This enables

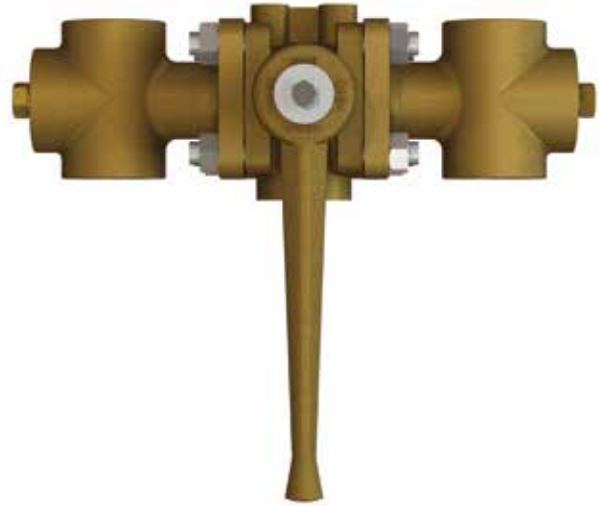

DN20 Bronze Flow Diverter Ball Valve

the discharge of higher volumes of gas, which in turn allows faster filling or quicker tank turnaround. The second main advantage is that, even during movement of the operating lever from one position to another, the flow capacity of the valve is not reduced below that available from one fully open port. The integrity of the vessel is not threatened, therefore, even if the operator inadvertently leaves the operating lever mid-position.

The vital part that the diverter valve plays in the integrity of a storage system requires it to be designed with safety in mind. The following features help to ensure that the valve fulfils its role reliably:

- Anti-blow out stem
- Porting indications on handle
- Handle designed to prevent attachment to valve in wrong position
- Ball machined to prevent incorrect assembly
- Drilled and tapped mounting bosses to allow rigid mounting.

## Technical

- Designed and engineered for use with Group 1 gases.
- Designed and manufactured in accordance with ASTM B31.1, BS EN 1626 and BS ISO 21011.
- Optional full material traceability backed by BS EN 10204 3.1/3.2 certification.

CE Marked according to the Pressure Equipment Directive.



## Materials

	<b>Bronze</b>
1. Body	Gunmetal BS EN 1982 CC491K
2. End Adaptors	Gunmetal BS EN 1982 CC491K
3. Stem	HT Brass BS EN 12164 CW721R
4. Lever	Gunmetal BS EN 1982 CC491K
5. Ball	Brass
6. Seat, Gland	Virgin PTFE
7. Fasteners	Stainless Steel BS6105 A2/A4 Gr.70

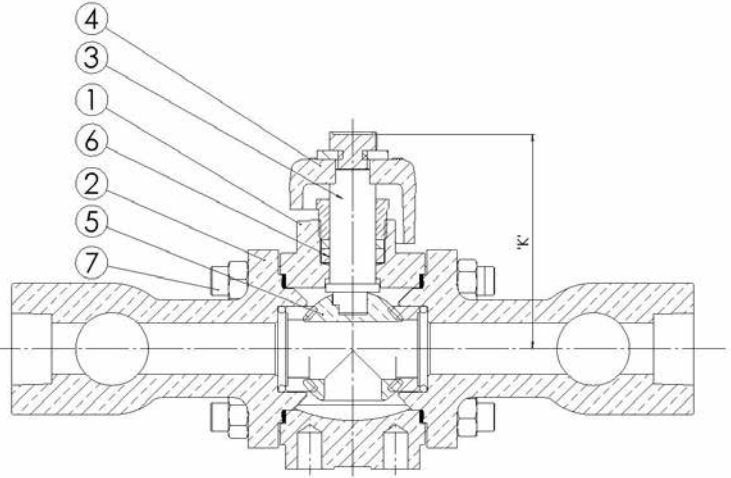

## Specifications

	<b>Unit</b>	<b>DN20</b>	<b>DN25</b>	<b>DN32</b>	<b>DN50</b>
F	mm	170	170	225	225
G	mm	44	60	67.5	95
J	mm	168	200	223	222
K	mm	75	75	75	75
Weight	kg	6	8.2	12	19
CV	US	10.8	19	31	84
	GPM	(1 port)	(1 port)	(1 port)	(1 port)

### End Adaptors Configuration

The main function of the end flanges is to duct the flow from the centre body to the relief valves. In addition to this primary function however, is the subsidiary one of providing additional ports to allow connection of pressure test apparatus and/or bursting disc.

Note that the end flanges can be fitted in any one of four positions, each at 90° to the other. The operating arc of the valve lever may prevent several of these positions being used because of the 180° lever operation.

A	Outlet Connection 1
D	Outlet Connection 2
E	Outlet Connection 3
F	Lever Length
G	Inlet Length
H	Inlet Connection
J	Dimension over outlet centres
K	Stem Length

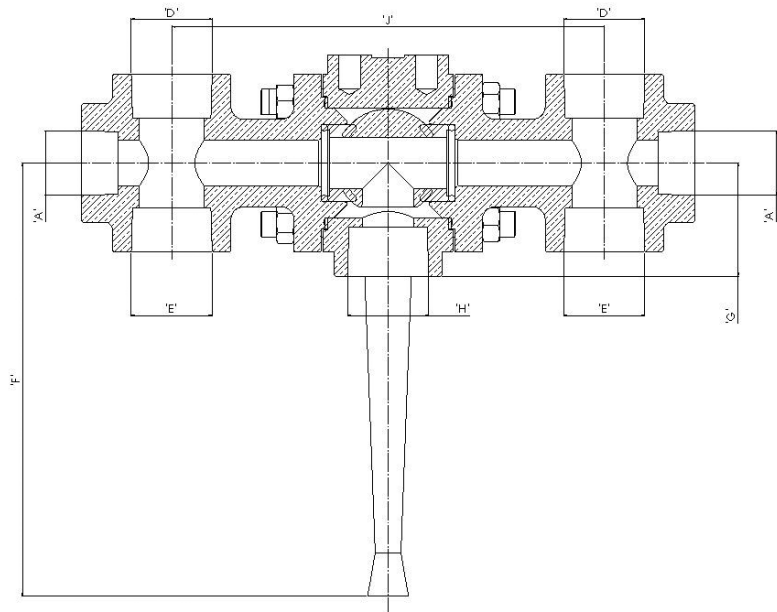

# Flow Diverter Ball Valve

Bronze

DN20 - DN50 (3/4" - 2")

## How to Order

Part Number	Outlet			Inlet Connection	Entry
	Connection 1	Connection 2	Connection 3		
<b>DN20 Diverter</b>					
CJB40SS5ABT1T	-	3/4" PL	3/4" PL	1" NB	Bottom
CJB40TA5AAT1T	-	1/2" PL	1/2" PL		
CJB40TE5BZT1T	3/4" NPT	1" NPT	1" NPT	1"NPT	
CJF40SS5APT1T	1/4" NPT	3/4" NPT	3/4" NPT		
CJF40SS5B2T1T	-	1" PL	1" PL	1" NB	
CJF40555H4E1T	1/4" NPT Plugged	1/2" NPT	1/2" NPT		
CJF40555H6E1T		1" TR	1" TR		
CJF40TA5AKE1TVA	1/2" PL Plugged	3/8" PL Plugged	3/4" PL	1"PL	Front
CJF40TC5B8E1TVA	3/4" TR Plugged	1/4" NPT	3/4" TR	1" TR	
CJF40TE5APT1T	1/4" NPT	3/4" NPT Plugged	3/4" NPT	1" NPT	
CJF40TE5BEE1TVA	-				
CJF40TE5BFE1TVA	-	1/2"NPT Plugged	1/2" NPT		
CJF40TH5B8E1TVA	-	1/2" PL	1/2" PL	M40/2	
<b>DN25 Diverter</b>					
CJF50TE5APE1T	1/4" NPT	3/4" NPT	3/4" NPT	1"NPT	Bottom
<b>DN32 Diverter</b>					
CJF60SS7BEE1T	-	1 1/4" TR	1 1/4" TR	1 1/2" NB	Front
CJF60SS7CHE1T	1/4" NPT	3/4" NPT	1" NPT		
CJF60SS7CJEITQ5	-	1" TR	1" TR	1 1/2" NPT	
CJF60SS7CLE1T	1/4" NPT	1" NPT	1" NPT		
CJF600SS7CLE1T		1" NPT	1" NPT		
CJF60TC6BE1T	-	1 1/4" TR	1 1/4" TR	1 1/2" TR	
CJB60TE6C9E1T	1 1/2" NPT	-	-	1 1/2" NPT	Bottom

Part Number	Outlet			Inlet Connection	Entry
	Connection 1	Connection 2	Connection 3		
<b>DN50 Diverter</b>					
CJB80TA6E4T1T	3/8" TR	1 1/4" PL	1 1/4" PL	1 1/2" NB	Bottom
CJB08TA6EDT1T		1 1/2" PL	1 1/2" PL		
CJB80TC7FGE1T	-	1" TR	1" TR	2" TR	
CJF80SS6F4TITQC	1/4" TR		1 1/4" TR	1 1/2" NB	
CJF80TC7EPEITVA	3/4" TR Plugged	1/4" NPT Plugged		2" TR	Front
CJF80SS7F2T1T	-	2" TR	2" TR	2" NB	
CJF807FDEITVA	1" TR Plugged	1/4" NPT Plugged	3/4" NPT		
CJF80TC7F6E1T	3/4" TR	1/4" NPT	3/4" TR	2" TR	
CJF80TC7EDE1T	-	1 1/2" TR	1 1/2" TR		

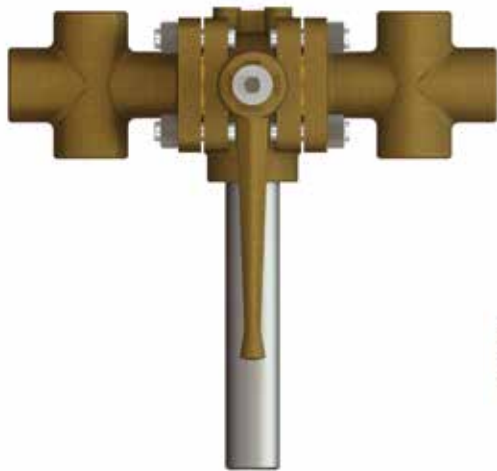

DN50 with Stainless Inlet Tube



DN20 (1" Coupling) with Safety Relief Valves

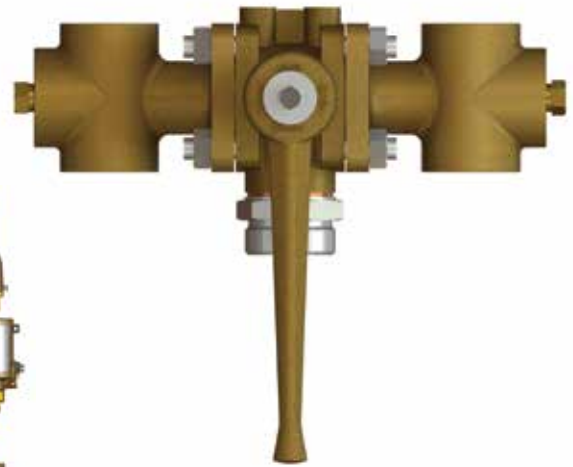

DN50 with Stainless Inlet Adaptor

# Flow Diverter Globe Valve

Bronze  
DN25 (1")

The Parker Bestobell flow diverter is a quarter turn ball valve design allowing for fast changeover between relief valves.

It is essential that a cryogenic liquid storage vessel is always protected by a relief valve. If only one relief valve was fitted to the vessel it would be impossible to disconnect for routine maintenance or checking of lifting pressures without prejudicing the safety of the vessel.

For this reason, all cryogenic storage tanks require two relief valves to be connected to the tank via a flow diverter valve. This allows one relief valve to remain connected to the vessel while the other undergoes maintenance.

This valve is usually at the hub of a fairly complex piping system and many variations on the basic design have evolved to suit customers' specific requirements.

All valves are degreased for oxygen duty, assembled in clean room conditions and pressure tested prior to dispatch.



DN25 Bronze Flow Diverter Globe Valve



DN25 with Inlet Adaptor

## Technical

- Designed and engineered for use with Group 1 gases.
- Designed and manufactured in accordance with ASTM B31.1, BS EN 1626 and BS ISO 21011.
- Optional full material traceability backed by BS EN 10204 3.1/3.2 certification.

CE Marked according to the Pressure Equipment Directive.

## Materials

	<b>Bronze</b>
1. Body	Gunmetal BS EN 1982 CC491K
2. Cover	Gunmetal BS EN 1982 CC491K
3. Stem	HT Brass BS EN 12164 CW721R
4. Seal	Hostaflon 25% Glass Filled PTFE
5. Gasket	Sigma 511
6. Packings	Virgin PTFE

## Specifications

Size	Unit	DN25 1"		
A	mm	70	A	Outlet centre to Inlet centre
B	mm	70	B	Outlet centre to Inlet centre
E	mm	93	C	Outlet Connection 1
G	mm	116	D	Inlet Connection 1
H	mm	230	E	Dimension over Outlet centres
J	mm	258	F	Outlet Connection 2
CV	US GPM	6.5	G	Handwheel Diameter
Weight	kg	5.6	H	Bottom Port
			J	Top Port

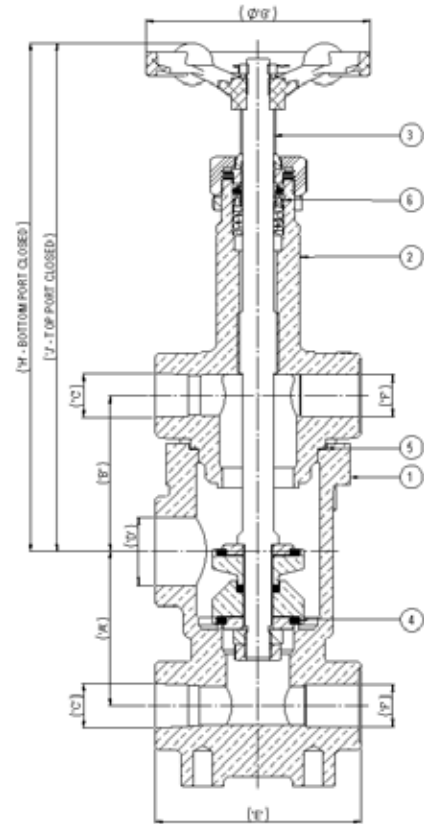

## How to Order

Part Number	Outlet Connection 1	Inlet Connection 1	Outlet Connection 2
CND50MRL1FA12	½" BSP-PL	1" BSP-PL	½" BSP-TR
CND50MRL1FA19	½" NPT	1" NPT	¾" NPT
CND50MRL1FA23			½" NPT

# Low Flow Protection Switch - Truflo

Bronze DN10 - DN40 (3/8" – 1 1/2")

The Parker low flow protection switch - Truflo ensures protection against flow changes that could be detrimental to equipment and processes, warning against insufficient flow as standard or to warn against excessive flow on request. The Truflo functions by diaphragm action brought about by a flow through a calibrated nozzle. The movement of the diaphragm is used to operate a microswitch.

The underside of the diaphragm is in direct contact with the inlet flow, the upper side with the outlet flow from the calibrated nozzle. With no flow through the Truflo a spring loaded plunger holds the diaphragm in the down position.

Flow through the calibrated nozzle causes a pressure differential between top and bottom of the diaphragm, with the higher pressure on the underside of the diaphragm, pushing it upwards. This in turn causes the plunger to move, which activates the microswitch.

## Features

To warn against insufficient flow as standard or to warn against excessive flow on request.

- Life Expectancy - 500,000 operations @ 15amps / 6,000,000 operations @ 5amps
- Main Diaphragm – EPDM (Silicone available on request)
- Electrical Data:
  - 125,250 or 480V AC-15 amps
  - 250V DC-1/4 amp
  - 125V DC-1/2 amp

## Materials

	Bronze
1. Body	Gunmetal BS EN 1982 CC491K
2. Flange Plate	Naval Brass BS EN 12163 CW712R
3. Pressure Plate	SS 316 BS EN 10088-3 1.4401
4. Plunger	Naval Brass BS EN 12163 CW712R
5. Main Diaphragm	Nitrile (Standard)
6. Nozzle	Naval Brass BS EN 12163 CW712R
7. Cover Lid	Gunmetal BS EN 1982 CC492K
8. Microswitch	Plastic



DN15 Bronze Truflo

## Maximum Working Pressure (MWP)

- Max. Working Pressure: 150psi (10.6 kg/cm<sup>2</sup>)
- Min. Working Pressure: 3psi (0.21 kg/cm<sup>2</sup>)
- Pressure Differential to Activate Switch: 2psi
- Max Temp: 70 °C (160 °F)
- Min Temp: 1 °C (34 °F)

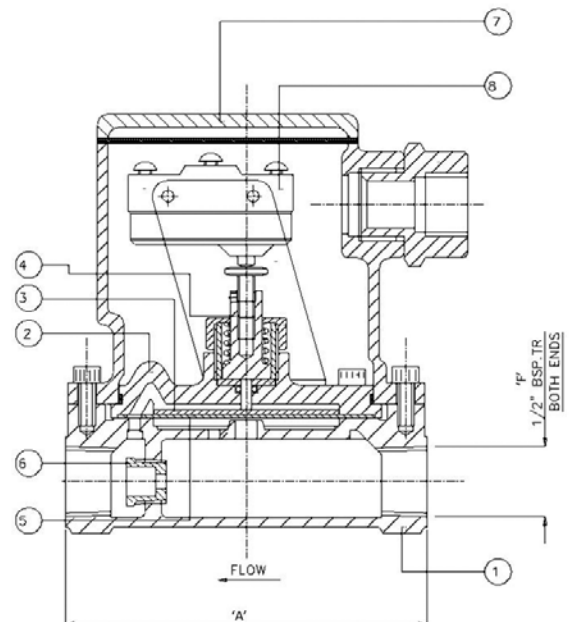

## Installation

1. It is advisable that the Truflo switch be fitted downstream of all items of equipment which require its protection. Should a Truflo be fixed upstream, and a burst takes place downstream, then no warning will be given.
2. Always fit a Truflo switch in a non-turbulent part of the circuit, i.e. always away from needle valves, sharps bends, etc., as these can cause switch 'Flutter'.
3. Do not grip the switch bracket when installing, always use the spanner flats provided. Do not use excessive pressure when making connections on to the terminals.
4. The Truflo switch is a precision, factory calibrated instrument, and any interference with its setting or with the switch mounting brackets will result in a variation of the flow warning rate.
5. The switch may be connected to a warning light, cut-off switch, or contactor relay.
6. For low flow rates, particularly of 1/2 G.P.M. and below, and where the fluid is likely to be unclean, we recommend that a strainer be fitted upstream.
7. If it is desired to restrict excess flow whilst protecting against minimum flow we suggest fitting a 'Constaflo' flow control unit upstream of the Truflo, this should be chosen to give a flow-rate of 50% above critical. The total pressure drop requirement then being 18 psi.

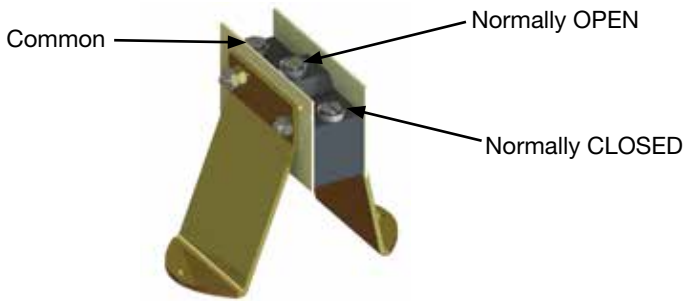
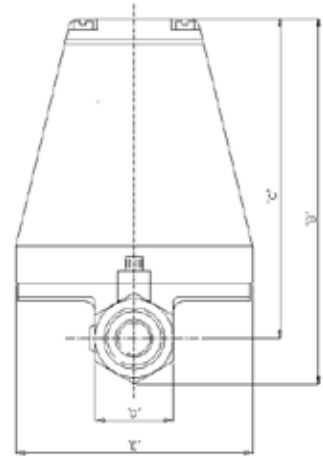

## Specifications

Size	1/2" B.S.P.T.	1 1/4" B.S.P.T.
A	108mm	113mm
B	125mm	153mm
C	109mm	120mm
D	27mm	51mm
E	82mm	82mm
F	1/2" B.S.P.T.	1 1/4" B.S.P.T.

## How to Order

The correct part number is easily derived from the following number sequence

FT	30	TA	14	B	A1	B
Series	Valve Size Diameter Nominal (DN)	Connection Type	Flow Rate (GPM)	Valve Body Material	Application	Diaphragm Material
FT Truflo	30 DN15	TA BSP-PL	14 0.375    36 4.000	B Bronze	A2 Industrial	B Silicone
	40 DN20	TC BSP-TR	15 0.400    37 4.500		A3 Marine	E EPDM
	50 DN25		16 0.450    38 5.000			
	60 DN32		17 0.500    39 5.500			
			20 0.625    41 6.250			
			24 1.000    43 7.000			
			25 1.125    45 8.000			
			26 1.250    47 9.000			
			27 1.375    48 10.000			
			28 1.500    50 11.000			
			30 2.000    52 12.500			
			31 2.250    58 16.000			
			33 2.750    61 18.000			
			34 3.000			

Please contact us for other options.

# Water Flow Controller - Constaflor

Bronze

DN6 - DN50 (1/4" - 2")

The Parker Constaflor is a water flow controller maintaining of flow rates with  $\pm 10\%$  of its rated capacity when operating within the limits of temperature and pressure specified in the 'Maximum Working Pressure' section.

## Maximum Working Pressure (MWP)

- Max. Working Pressure: 200psi (14kg/cm<sup>2</sup>)
- Max. Working Temperature: 65 °C
- Min. Working Temperature: 1 °C
- Max. Pressure Difference: 200psi (14kg/cm<sup>2</sup>)
- Min. Pressure Difference: 15psi (1.06kg/cm<sup>2</sup>)
- Accuracy  $\pm 10\%$  when operating in the range 15 to 200psi (1.06 to 14kg/cm<sup>2</sup>) pressure difference

## Operation

An EPDM diaphragm, working in conjunction with a profiled orifice - when subjected to pressure differences between 15 and 200psi (1.06 and 14kg/cm<sup>2</sup>) flexes on to the orifice to vary the orifice area, so maintaining a rate of flow irrespective of varying upstream or downstream pressures, within the operating range of the unit. An initial pressure drop of 15psi (1.06kg/cm<sup>2</sup>) is necessary before the unit reaches control point.

## Materials

	DN6-DN15
1. Body	Gunmetal BS EN 1982 CC491K
2. Nozzle	HT Brass BS EN 12164 CW721R
3. Diaphragm	EPDM (or Silicone)
4. Gasket	Nylon 66

	DN20-DN50
1. Body	Gunmetal BS EN 1982 CC491K
2. Retainer	Gunmetal BS EN 1982 CC491K
3. Retainer Diaphragm	Rigid PVC
4. Nozzle	Acetal
5. Diaphragm	EPDM (or Silicone)
6. Fasteners	Aluminium Brz BS EN 12163 CW307G

1/4" & 1/2" Stainless Steel versions available on request



DN50 Bronze Constaflor



DN50 Sectioned View

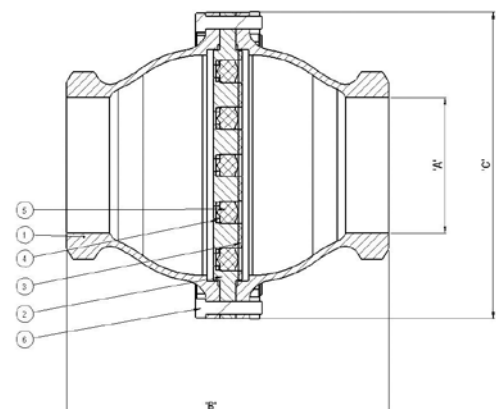
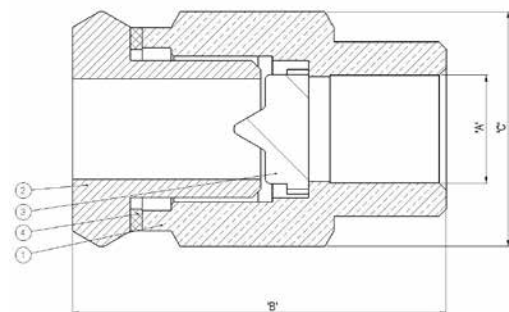



## Specifications

A		B		C	
in.	mm	in.	mm	in.	mm
1/4"	DN6	1 19/32	41	1/32	26
3/8"	DN10	2 1/32	51	1 1/4	32
1/2"	DN15	2 3/32	53	1 15/32	37
3/4"	DN20	3 17/32	91	2 7/8	73
1"	DN25	3 17/32	91	2 7/8	73
1 1/4"	DN32	6 3/16	157	5 1/4	133
1 1/2"	DN40	8 7/8	225	7 3/8	187
2"	DN50	10 5/8	270	8 3/8	213

## How to Order

The correct part number is easily derived from the following number sequence

FC	10		TA		03			B	C1		B		
Series	Valve Size Diameter Nominal (DN)		Connection Type		Flow Rate (GPM)			Valve Body Material	Applications		Diaphragm Material		
FC Constaflor	10	DN6	TA	BSP-PL	03	0.125	56	15.000	B Bronze	C1	Industrial	B	Silicon
	20	DN10	TC	BSP-TR	09	0.111	58	16.000		C2	Marine	E	EPDM
	30	DN15	TE	NPT	13	0.375	59	17.000					
	40	DN20			17	0.500	61	18.000					
	50	DN25			20	0.625	63	20.000					
	60	DN32			21	0.750	64	22.000					
	70	DN40			23	0.875	65	24.000					
	80	DN50			24	1.000	66	25.000					
					26	1.250	67	26.000					
					28	1.500	68	28.000					
					29	1.750	69	30.000					
					30	2.000	71	35.000					
					32	2.500	73	40.000					
					34	3.000	75	45.000					
					36	4.000	77	50.000					
					37	4.500	78	55.000					
					38	5.000	80	60.000					
					40	6.000	81	65.000					
					45	7.000	83	70.000					
					47	9.000	85	75.000					
				48	10.000	87	80.000						
				50	11.000	89	85.000						
				51	12.000	90	90.000						
				53	13.000	93	95.000						
				55	14.000	95	100.000						

### Notes:

DN6-DN15 - Single Constaflor up to 6 GPM

DN20-DN50 - Multi Constaflor up to 100 GPM

Please contact us for other options.

# Spares Kits

## Globe Valves & Manifold Fill Assemblies Soft Goods Kit

DN6 - DN150 (1/8" - 6")

Soft Goods Kit to suit cryogenic globe valves and manifold fill assemblies.

### Consisting of:

- 1 x Wiper Seal
- 2 x Chevron Top
- 1 x 'O' Seal
- 1 x Chevron BTM
- 1 x Gasket
- 1 x A/F Disc
- 1 x Seal



Soft Goods Kit for Globe Valves & Manifold Assemblies

### Specifications & How to Order

DN	Part Number	Weight (kg)
6	CNBR30C	0.1
10	CNBR30C	0.1
15	CNBR30C	0.1
20*	CNBR40C	0.1
25	CNBR50C	0.1
32	CNBR70C	0.1
40	CNBR70C	0.1
50	CNBR80C	0.1
65	CNBR90C	0.1
80	CNBRA0C	0.2
100	CNBRB0C	0.2
150	CNBRD0C	0.2

\*Suitable for use with Bronze Globe Valves only

# Globe Valves, Gate Valves, Manifold Fill Assemblies & Globe Diverters - Handwheels

## DN6 - DN150 (1/8" - 6")

Spare Handwheel to suit cryogenic globe valves, gate valves, manifold fill assemblies and globe diverters.

### Consisting of:

- 1 x Handwheel



Handwheel

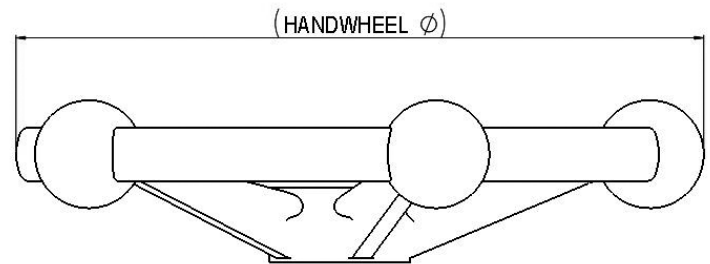

### Specifications & How to Order

DN	Part Number	Handwheel - Ø mm	Weight (kg)
6	S-M0F122M1AAB3W00	63.5	0.05
10	S-M0F122M1AAB3W00	63.5	0.05
15	S-M0F122M1AAB3W00	63.5	0.05
20	S-M0F122M1ABB5W00	82.55	0.09
25	S-M0F122M1ABB5W00	82.55	0.09
32	S-M0F122M1ACB7W00	101.6	0.1
40	S-M0F122M1ACB7W00	101.6	0.1
50	S-M0F121M1AHB8W00	127.0	0.2
65	S-M0F122M1AQB9W01	152.4	0.25
80	S-M0F121M1ATC2W00	203.2	0.4
100	S-L0210F017	380.0	7.00
150	S-M0F123H1CLC5B00	600.0	14.00

All weights are approximate

# Spares Kits

## Gate Valves – Wedge Disc Assembly DN40 - DN100 (1½” - 4”)

Disc and seal assembly replacements for cryogenic gate valves.

**Consisting of:**

- 1 x Disc (Phosphor Bronze) & Seal (Virgin PTFE)
- 1 x Locknut
- 1 x Spring Pin

**Specifications & How to Order**

Manual			Actuated		
DN	Part Number	Weight (kg)	DN	Part Number	Weight (kg)
40	S-SUBCMT7004002	0.1	-	-	-
50	S-SUBCMT8004002	0.3	50	S-SUBCMD8004000	0.3
65	S-SUBCMT9004002	0.4	65	S-SUBCMD9004000	0.4
80	S-SUBCMTA004002	0.6	80	S-SUBCMDA004001	0.6
100	S-SUBCMTA004002	0.6	-	-	-

All weights are approximate



Wedge Disc Assembly

## Gate Valves - Soft Goods Kit DN40 - DN100 (1½” - 4”)

Soft Goods Kit to suit cryogenic gate valves.

**Consisting of:**

- 1 x Wiper Seal
- 1 x Gland Packing Set
- 1 x Gasket

**Specifications & How to Order**

DN	Part Number	Weight (kg)
40	CMCR70	0.1
50	CMCR80	0.1
65	CMCR90	0.1
80	CMCRA0	0.1
100	CMCRA0	0.1

All weights are approximate

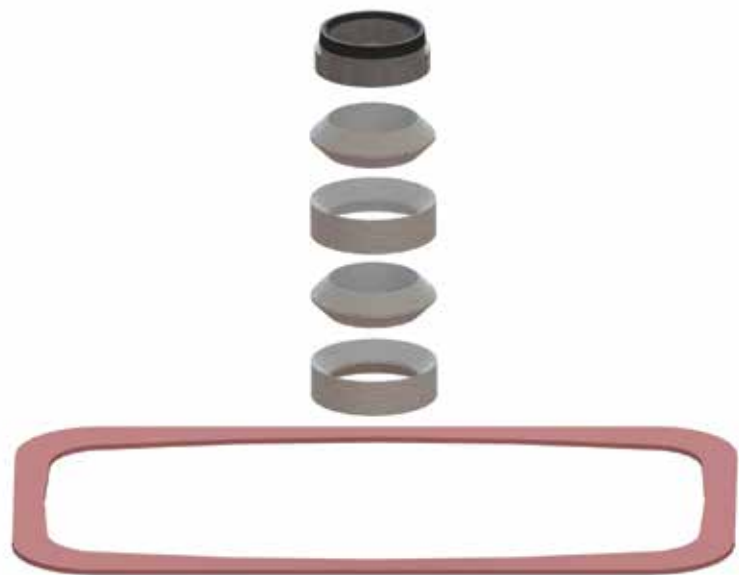

Soft Goods Kit for Gate Valves

# Ball Valves – Soft Goods Kit DN15 - DN50 (1/2" - 2")

Cryogenic ball valve soft goods kit.

**Consisting of:**

- 2 x Inner/Outer Ball Seal
- 1 x Wiper Seal
- 2 x Chevron Top
- 1 x Chevron Bottom
- 1 x PTFE Bush
- 1 x Protection Cap
- 1 x 'O' Seal
- 1 x Gasket
- 2 x Brass Washer
- 1 x Spring
- 1 x Shim



Soft Goods Kit for Ball Valves

**Specifications & How to Order**

DN	Bore	Part Number	Weight (kg)
10	Full	CZREPKIT15RB	0.1
15	Reduced	CZREPKIT15RB	0.1
20	Full	CZREPKIT25RB	0.1
25	Reduced	CZREPKIT25RB	0.1
25	Full	CZREPKIT40RB	0.1
40	Reduced	CZREPKIT40RB	0.1
40	Full	CZREPKIT50RB	0.1
50	Reduced	CZREPKIT50RB	0.1
65	Full	CZ0P65/80	0.3
80	Reduced	CZ0P65/80	0.3

All weights are approximate

# Spares Kits

## Gate Valves – Seat DN50 - DN100 (2" - 4")

Cryogenic gate valve replacement seat.

### Consisting of:

- 1 x Seat (316L) & Seal (Virgin PTFE)
- 1 x Circlip



Seat

### Specifications & How to Order

DN	Part Number	Weight (kg)
50	CMCR80SEAT	0.3
65	CMCR90SEAT	0.4
80	CMCRA0SEAT	0.5
100	CMCRA0SEAT	0.5

All weights are approximate

## Lift Check Valves – Soft Goods Kit DN6 - DN150 (1/8" - 6")

Soft Goods Kit to suit cryogenic lift check valves.

### Consisting of:

- 1 x Gasket
- 1 x Seal



Gasket & Seal

### Specifications & How to Order

DN	Part Number	Weight (kg)
6	CGR30C	0.1
10	CGR30C	0.1
15	CGR30C	0.1
20*	CGR40C	0.1
25	CGR50C	0.1
32	CGR70C	0.1
40	CGR70C	0.1
50	CGR80C	0.1
65	CGR90C	0.1
80	CGRA0C	0.1
100	CGRB0C	0.1
150	CGRD0C	0.1

\*Suitable for use with Bronze Lift Check Valves only  
All weights are approximate

# Cryogenic Pressure Regulators – Spares Kits DN15 (1/2")

Spares kits for Cryogenic Pressure Regulators.

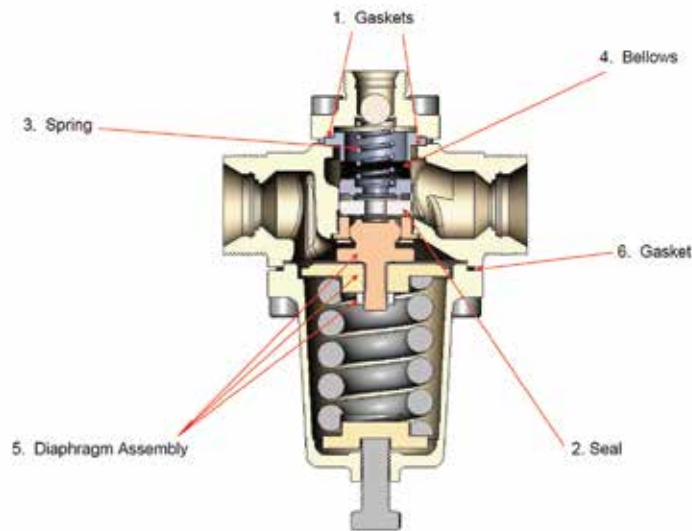

Cryogenic Pressure Regulator

## Specifications & How to Order

Part Number	Item	Content	DN	Weight (kg)
CKCSP1	Seal Kit	1 x Seal 2 x Gaskets	15	0.1
CKCSP2	Bellow/Seal Kit	1 x Bellows 1 x Spring 1 x Seal 2 x Gaskets	15	0.1
CKCSP3	Diaphragm Kit - High Pressure	1 x Diaphragm Assembly 1 x Gasket	15	0.5
CKCSP4	Diaphragm Kit – Low Pressure	1 x Diaphragm Assembly 1 x Gasket	15	0.5
CKCSP5	Main Spring Kit – High Pressure	1 x Spring 1 x Gasket	15	0.7
CKCSP6	Main Spring Kit – Medium Pressure	1 x Spring 1 x Gasket	15	0.4
CKCSP7	Main Spring Kit – LowPressure	1 x Spring 1 x Gasket	15	0.4
CKCSP8	Gasket Set	2 x Gaskets 1 x Gasket	15	0.1
CK30A1REPKITHP	Repair Kit – High Pressure	1 x Diaphragm Kit - High Pressure 1 x Seal 2 x Gaskets	15	0.1
CK30A1REPKITLP	Repair Kit – Low Pressure	1 x Diaphragm Kit – Low Pressure 1 x Seal 2 x Gaskets	15	0.5

All weights are approximate

# Spares Kits

## Swing Check Valves – Disc, Seal Assembly & Gasket DN50 - DN100 (2” - 4”)

Spares kit to suit cryogenic swing check valves.

### Consisting of:

- 1 x Gasket
- 1 x Disc (316) & Seal (Virgin PTFE)
- 1 x Split Pin

### Specifications & How to Order

DN	Part Number	Weight (kg)
25	CHCR50	0.1
40	CHCR70	0.1
50	CHCR80	0.2
80	CHCRA0	0.4

All weights are approximate



Disk, Seal Assembly & Gasket

## Strainer – Soft Goods Kit DN6 - DN150 (1/8” - 6”)

Spare Gasket to suit cryogenic globes, lift checks & strainers.

### Consisting of:

- 1 x Gasket

### Specifications & How to Order

DN	Part Number	Weight (kg)
6	S-B0A61BLZ76A90000	0.01
10	S-B0A61BLZ76A90000	0.01
15	S-B0A61BLZ76A90000	0.01
20	S-B0A61BLZA9A90000	0.01
25	S-B0A61BLZA9A90000	0.01
32	S-B0A61BLZCBA90000	0.01
40	S-B0A61BLZCBA90000	0.01
50	S-B0A61BLZEDA90000	0.01
65	S-B0A61BLZFEAC0000	0.01
80	S-B0A61BR176AC0020	0.01
100	S-B0A61BL5HGAC0000	0.01
150	S-B0A61BL2KKAC0000	0.01

All weights are approximate



Gasket



## Ball Diverter Valves – Soft Goods Kit DN20 - DN50 (3/4" - 2")

Soft Goods Kit to suit cryogenic ball diverters.

### Consisting of

- 2 x Ball Seal
- 2 x End Cover Gasket
- 2 x 'O' Seal
- 1 x Packing
- 2 x Support to Valve Seal (Only on DN32 & DN50 versions)

### Specifications & How to Order

DN	Part Number	Weight (kg)
20	CJR40	0.1
32	CJR60	0.1
50	CJR80	0.2

All weights are approximate



Soft Goods Kit for Ball Diverter Valves

## Globe Diverter Valves – Soft Goods Kit DN25 (1")

Soft Goods Kit to suit cryogenic globe diverter valves.

### Consisting of:

- 1 x Wiper Seal
- 1 x Chevron Set
- 2 x Brass Washer
- 1 x Gasket
- 2 x Outer Seal
- 1 x Inner Seal
- 1 x Spring

### Specifications & How to Order

DN	Part Number	Weight (kg)
25	CNDR50	0.1

All weights are approximate



Soft Goods Kit for Globe Diverter Valves

# Spares Kits

## Pressure Build Up Valves – Gasket, Seal & Bellows DN50 (2")

Soft Goods Kit to suit DN50 Pressure Build Up Valves.

### Consisting of:

- 1 x Bellows
- 1 x Seal
- 1 x Gasket

### Specifications

DN	Part Number	Weight (kg)
50	CFR80	0.3

All weights are approximate

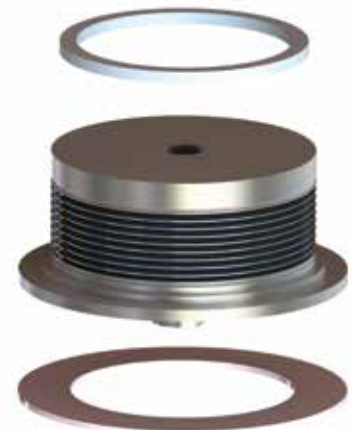

Gasket, Seal & Bellows

## Constaflo – Diaphragm, Nozzle & Gasket DN6 - DN50 (1/4" – 2")

Spares kits to suit Constaflo Valves

### Consisting of:

- Orifice Plate Sub Assembly
- Diaphragm (EPDM) & Nozzle
- Gasket & 'O' Seal



Gasket & 'O' Seal



DN6 Bronze Diaphragm & Nozzle



DN10-DN50  
Acetal Diaphragm & Nozzle

### Specifications & How to Order

Part Number	DN	Weight (kg)
<b>Diaphragm &amp; Nozzle</b>		
FC10SP--BE	6	0.2
FC20SP--BE	10	0.1
FC30SP--BE	15	0.1
FC40SP--BE	20	0.2
FC50SP--BE	25	0.2
FC60SP--BE	32	0.3
FC70SP--BE	40	0.4
FC80SP--BE	50	0.5
<b>Gasket</b>		
S-B0A61BN354AB0000	6	0.1
S-B0A61BN376AB0000	10	0.1
S-B0A61BN376AB0000	15	0.1
S-B0A61BJBBAC0000	20	0.1
S-B0A61BJBBAC0000	25	0.1
<b>'O' Seal</b>		
S-B0A60JJ1D100	32	0.1
S-B0A60JJ1DA00	40	0.1
S-B0A60JJ1DD00	50	0.1

All weights are approximate

# Truflo – Nozzle & Diaphragm

## DN10 - DN40 (3/8" - 1 1/2")

Spares Kit to suit Truflo Valves.

### Consisting of:

- 1 x Nozzle
- 1 x Diaphragm

### Specifications & How to Order

DN	Nozzle		Diaphragm	
	Part Number	Weight (kg)	Part Number	Weight (kg)
10	S-MFT31DC5302600	0.2	S-BFT24CJ100	0.1
15	S-MFT31DC5302600	0.2	S-BFT24CJ100	0.1
20	S-MFT31DC5302600	0.2	S-BFT24CJ100	0.1
25	S-MFT31DC5302600	0.2	S-BFT24CJ100	0.1
32	S-MFT31DA2603700	0.2	S-BFT24CJ100	0.1
40	S-MFT31DA2603700	0.2	S-BFT24CJ100	0.1

All weights are approximate



Nozzle



Diaphragm

# Actuated Gate Valves – Soft Goods Kit & Tyre

## DN50 - DN80 (2" - 3")

Spares kits to suit cryogenic actuated gate valves.

### Consisting of:

Soft Goods Kit:

- 1 x Wiper Seal
- 1 x Gland Packing Set
- 1 x Gasket

Tyre:

- 1 x Spare Tyre

### Specifications & How to Order

Soft Goods Kit			Tyre		
DN	Part Number	Weight (kg)	DN	Part Number	Weight (kg)
50	CMCR80	0.4	50	S-L0708F012	2
65	CMCR90	0.4	65	S-L0708F012	2
80	CMCRA0	0.4	80	S-L0708F012	2

All weights are approximate

Both kits supplied separately



Soft Goods Kit

Tyre

# Useful Conversion Charts

Gases Conversion Table				
Gas	*m3 gas per kilogram	*m3 gas per litre of liquid	Boiling point °C	Relative Density
Oxygen	0.738	0.842	-183	1.1
Nitrogen	0.844	0.682	-196	1.0
Carbon Dioxide	0.535	-	-78#	1.5
Argon	0.591	0.822	-186	1.4
Air	0.816	-	-194	1.0
Helium	5.913	0.737	-269	0.14
Hydrogen	11.73	0.831	-253	0.07
LPG (85% Propane)	0.531	0.271	-42	2.0
Acetylene	0.901	-	-75	0.9
Sulphur Dioxide	0.366	0.534	-10	2.3
Nitrous Oxide	0.534	0.654	-89	1.5
At 15°C and 101.33 kPa				#dry ice (solid)

<b>Bar to psi</b>	Divide psi figure by 14.5
<b>Bar to kg per cm2</b>	Bar multiplied by 1.0197
<b>mbar to kpa</b>	mbar multiplied x 0.1
<b>kpa to bar</b>	Divide by 100
<b>mpa to bar</b>	Multiply by 10
<b>kg per cm2 to bar</b>	Multiply by 0.98
<b>1 UK gallon</b>	4.546 litres
<b>1 UK gallon</b>	1.201 US gallon
<b>1 US gallon</b>	3.785 litres
<b>1 kilogram</b>	2.2 lb

# Notes

# Notes

# Notes

# Sales Offices Worldwide

## Europe, Middle East, Africa

### AE – United Arab Emirates, Dubai

Tel: +971 4 8127100  
parker.me@parker.com

### AT – Austria, Wiener Neustadt

Tel: +43 (0)2622 23501-0  
parker.austria@parker.com

### AT – Eastern Europe, Wiener Neustadt

Tel: +43 (0)2622 23501 900  
parker.easteurope@parker.com

### AZ – Azerbaijan, Baku

Tel: +994 50 2233 458  
parker.azerbaijan@parker.com

### BE/LU – Belgium, Nivelles

Tel: +32 (0)67 280 900  
parker.belgium@parker.com

### BG – Bulgaria, Sofia

Tel: +359 2 980 1344  
parker.bulgaria@parker.com

### BY – Belarus, Minsk

Tel: +48 (0)22 573 24 00  
parker.poland@parker.com

### CH – Switzerland, Etoy

Tel: +41 (0)21 821 87 00  
parker.switzerland@parker.com

### CZ – Czech Republic, Klecany

Tel: +420 284 083 111  
parker.czechrepublic@parker.com

### DE – Germany, Kaarst

Tel: +49 (0)2131 4016 0  
parker.germany@parker.com

### DK – Denmark, Ballerup

Tel: +45 43 56 04 00  
parker.denmark@parker.com

### ES – Spain, Madrid

Tel: +34 902 330 001  
parker.spain@parker.com

### FI – Finland, Vantaa

Tel: +358 (0)20 753 2500  
parker.finland@parker.com

### FR – France, Contamine s/Arve

Tel: +33 (0)4 50 25 80 25  
parker.france@parker.com

### GR – Greece, Athens

Tel: +30 210 933 6450  
parker.greece@parker.com

### HU – Hungary, Budaörs

Tel: +36 23 885 470  
parker.hungary@parker.com

### IE – Ireland, Dublin

Tel: +353 (0)1 466 6370  
parker.ireland@parker.com

### IL – Israel

Tel: +39 02 45 19 21  
parker.israel@parker.com

### IT – Italy, Corsico (MI)

Tel: +39 02 45 19 21  
parker.italy@parker.com

### KZ – Kazakhstan, Almaty

Tel: +7 7273 561 000  
parker.easteurope@parker.com

### NL – The Netherlands, Oldenzaal

Tel: +31 (0)541 585 000  
parker.nl@parker.com

### NO – Norway, Asker

Tel: +47 66 75 34 00  
parker.norway@parker.com

### PL – Poland, Warsaw

Tel: +48 (0)22 573 24 00  
parker.poland@parker.com

### PT – Portugal

Tel: +351 22 999 7360  
parker.portugal@parker.com

### RO – Romania, Bucharest

Tel: +40 21 252 1382  
parker.romania@parker.com

### RU – Russia, Moscow

Tel: +7 495 645-2156  
parker.russia@parker.com

### SE – Sweden, Spånga

Tel: +46 (0)8 59 79 50 00  
parker.sweden@parker.com

### SK – Slovakia, Banská Bystrica

Tel: +421 484 162 252  
parker.slovakia@parker.com

### SL – Slovenia, Novo Mesto

Tel: +386 7 337 6650  
parker.slovenia@parker.com

### TR – Turkey, Istanbul

Tel: +90 216 4997081  
parker.turkey@parker.com

### UA – Ukraine, Kiev

Tel: +48 (0)22 573 24 00  
parker.poland@parker.com

### UK – United Kingdom, Warwick

Tel: +44 (0)1926 317 878  
parker.uk@parker.com

### ZA – South Africa, Kempton Park

Tel: +27 (0)11 961 0700  
parker.southafrica@parker.com

## North America

### CA – Canada, Milton, Ontario

Tel: +1 905 693 3000

### US – USA, Cleveland

Tel: +1 216 896 3000

## Asia Pacific

### AU – Australia, Castle Hill

Tel: +61 (0)2-9634 7777

### CN – China, Shanghai

Tel: +86 21 2899 5000

### HK – Hong Kong

Tel: +852 2428 8008

### IN – India, Mumbai

Tel: +91 22 6513 7081-85

### JP – Japan, Tokyo

Tel: +81 (0)3 6408 3901

### KR – South Korea, Seoul

Tel: +82 2 559 0400

### MY – Malaysia, Shah Alam

Tel: +60 3 7849 0800

### NZ – New Zealand, Mt Wellington

Tel: +64 9 574 1744

### SG – Singapore

Tel: +65 6887 6300

### TH – Thailand, Bangkok

Tel: +662 186 7000

### TW – Taiwan, Taipei

Tel: +886 2 2298 8987

## South America

### AR – Argentina, Buenos Aires

Tel: +54 3327 44 4129

### BR – Brazil, Sao Jose dos Campos

Tel: +55 800 727 5374

### CL – Chile, Santiago

Tel: +56 2 623 1216

### MX – Mexico, Toluca

Tel: +52 72 2275 4200



Parker Hannifin Manufacturing Ltd  
Instrumentation Products Division  
Europe

President Park, President Way  
Sheffield S4 7UR  
United Kingdom

Tel: +44 114 224 0000  
www.parker.com/ipd

EMEA Product Information Centre

Free phone: 00 800 27 27 5374

(from AT, BE, CH, CZ, DE, DK, EE, ES, FI,  
FR, IE, IL, IS, IT, LU, MT, NL, NO, PL, PT,  
RU, SE, SK, UK, ZA)

US Product Information Centre

Toll-free number: 1-800-27 27 537

www.parker.com